

Product Catalog 2024

# Industrial Pumps & Metering Systems

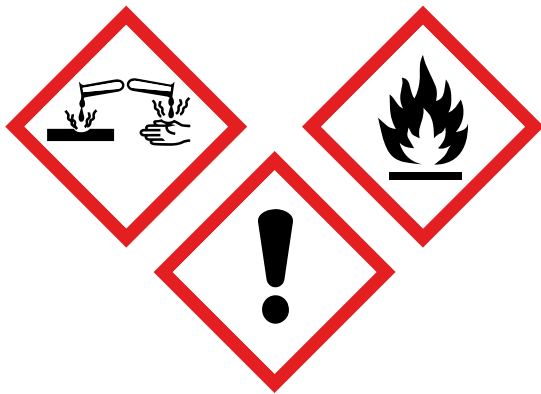

# TABLE OF CONTENTS

Pump Packages	4
Drum Pump Motors	8
Pump Tubes – PP, PPS, PHT, CPVC, PVDF	14
SP-MINI Series	24
Pump Tubes - Stainless Steel, Aluminum	26
Barrel Mixers	30
Hand Pumps	31
Accessories For Centrifugal Pumps	32
Heating Jackets (AtEx incl.) for 200 ltr. drums and 1000 ltr. IBC	34
AtEx Heating Jackets for 200 ltr. drums and 1000 ltr. IBC	34
Progressive Cavity Pumps and Lifting Device Systems	36
SP-700SR Progressive Cavity Series	38
SP-700DD Progressive Cavity Series	40
Motors for SP-700DD Pumps	42
Lifting Device Systems for Drum Pumps and Motors	46
Accessories for Progressive Cavity Pumps	47
Metering Systems	
Batch Control System – ELECTRIC (Low Viscosity)	48
Turbine Flow Meters – FMT 3	50
Turbine Flow Meters – FMOG	51
Systems	52
Warranty	53
Additional Markets Served	
PlusAir – Air Operated Dual Diaphragm Pumps	54
Pure Pump – Sanitary Drum- & AODD Pumps	55
QUANTM – Electric Operated Double Diaphragm Pumps	56
Industrial Mixers, Agitators.	57

# MARKETS SERVED



AUTOMOTIVE



WASTE WATER  
TREATMENT



CHEMICAL  
PACKAGING



PHARMACEUTICAL



PLATING



AGRICULTURE

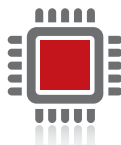

SEMI-CONDUCTOR



PETROLEUM

# Pump Packages



## Pump Package SPEK-PPS, A,B,C | Water Treatment Chemicals

Engineered to transfer corrosive chemicals associated with the Water Treatment Industry. Common applications include: Corrosion inhibitors and water additives.

<b>Motor Type</b>	SPE-250B
<b>Pump Assembly</b>	PPS
<b>Pump Length</b>	27" (700 mm), 39" (1000 mm) or 47" (1200 mm)
<b>Hose</b>	1,5 m I.D. ¾" x O.D 1" (25 mm) PVC
<b>Dispensing Nozzle</b>	¾", Polypropylene (Viton® or EPDM o-ring)
<b>Max. Flow Rate</b>	38 LPM <i>based on water</i>
<b>Max. Viscosity</b>	200 cps (mPas)
<b>Max. Temperature</b>	55 °C

Part Number	Voltage	Pump Length
SPEK-PPS-27	220-240V	27" (700 mm)
SPEK-PPS-39	220-240V	39" (1000 mm)
SPEK-PPS-47	220-240V	47" (1200 mm)

⚠ Warning: Not suitable for pumping flammable or combustible liquids.



## Pump Package 1 | Water Treatment Chemicals

Engineered to transfer corrosive chemicals associated with the Water Treatment industry. Common applications include: Sodium Hypochlorite, Potassium Hydroxide and Sodium Bromide.

<b>Motor Type</b>	SPE-950V (Variable Speed Drive)
<b>Pump Assembly</b>	CPVC
<b>Pump Length</b>	39" (1000 mm) or 47" (1200 mm)
<b>Hose</b>	1,8 m, I.D. 1" (25 mm) PVC
<b>Dispensing Nozzle</b>	1" (25 mm), Polypropylene (Viton® or EPDM o-ring)
<b>Barrel Adapter</b>	Polypropylene
<b>Storage Bracket</b>	Stainless Steel
<b>Max. Flow Rate</b>	67 LPM <i>based on water</i>
<b>Max. Viscosity</b>	1500 cps (mPas)
<b>Max. Temperature</b>	88 °C

Part Number	Voltage	Pump Length
9550	220-240V	39" (1000 mm)
9551	220-240V	47" (1200 mm)

⚠ Warning: Not suitable for pumping flammable or combustible liquids.



## Pump Package 2 | Acids & Alkalis

Engineered to transfer corrosive liquids. Common applications include: Hydrochloric Acid, Nitric Acid (20%), Acetic Acid and Sulfuric Acid.

<b>Motor Type</b>	SPE-950V (Variable Speed Drive)
<b>Pump Assembly</b>	Polypropylene
<b>Pump Length</b>	39" (1000 mm) or 47" (1200 mm)
<b>Hose</b>	1,8 m, I.D. 1" (25 mm) PVC
<b>Dispensing Nozzle</b>	1" (25 mm), Polypropylene (Viton® or EPDM o-ring)
<b>Barrel Adapter</b>	Polypropylene
<b>Storage Bracket</b>	Stainless Steel
<b>Max. Flow Rate</b>	67 LPM <i>based on water</i>
<b>Max. Viscosity</b>	1500 cps (mPas)
<b>Max. Temperature</b>	55 °C

Part Number	Voltage	Pump Length
9530	220-240V	39" (1000 mm)
9531	220-240V	47" (1200 mm)

⚠ Warning: Not suitable for pumping flammable or combustible liquids.





## Pump Package 3 | Concentrated Acids & Alkalies

Engineered to transfer very concentrated and extremely aggressive liquids. Common applications include: Sulfuric Acid 66 Baumé, Propionic Acid, Concentrated Nitric (98%) and Hydrofluoric Acid.

<b>Motor Type</b>	SPE-950V (Variable Speed Drive)
<b>Pump Assembly</b>	PVDF (Kynar®)
<b>Pump Length</b>	39" (1000 mm) or 47" (1200 mm)
<b>Hose</b>	1,8 m, I.D. 1" (25 mm) AtEx/Chemical Hose
<b>Dispensing Nozzle</b>	1" (25 mm), PVDF (Viton® or EPDM o-ring)
<b>Barrel Adapter</b>	Polypropylene
<b>Storage Bracket</b>	Stainless Steel
<b>Max. Flow Rate</b>	67 LPM <i>based on water</i>
<b>Max. Pressure</b>	10,6 m
<b>Max. Viscosity</b>	1500 cps (mPas)
<b>Max. Temperature</b>	80 °C

Part Number	Voltage	Pump Length
9580	220-240V	39" (1000 mm)
9581	220-240V	47" (1200 mm)

⚠ Warning: Not suitable for pumping flammable or combustible liquids.



## Pump Package 4 | Acids & Alkalies Measurement

Unique design allows users to safely measure and transfer corrosive liquids. Common applications include: Hydrochloric Acid, Nitric Acid (20%), Acetic Acid and Sulfuric Acid.

<b>Motor Type</b>	SPE-950V (Variable Speed Drive)
<b>Pump Assembly</b>	Polypropylene
<b>Pump Length</b>	39" (1000 mm) or 47" (1200 mm)
<b>Hose</b>	1,8 m, I.D. 1" (25 mm) PVC
<b>Dispensing Nozzle</b>	1" (25 mm), Polypropylene (Viton® or EPDM o-ring)
<b>Flow Meter</b>	Digital / Polypropylene
<b>Barrel Adapter</b>	Polypropylene
<b>Storage Bracket</b>	Stainless Steel
<b>Max. Flow Rate</b>	61 LPM <i>based on water</i>
<b>Max. Pressure</b>	10,6 m
<b>Max. Viscosity</b>	300 cps (mPas)
<b>Max. Temperature</b>	55 °C

Part Number	Voltage	Pump Length
9540	220-240V	39" (1000 mm)
9541	220-240V	47" (1200 mm)

⚠ Warning: Not suitable for pumping flammable or combustible liquids.



## Pump Package 5 | Concentrated Acids & Alkalies Measurement

Unique design allows operators to safely measure and transfer concentrated and very aggressive liquids. Common applications include: Sulfuric Acid 66 Baumé, Propionic Acid, Concentrated Nitric (98%) and Hydrofluoric Acid.

<b>Motor Type</b>	SPE-950V (Variable Speed Drive)
<b>Pump Assembly</b>	PVDF (Kynar®)
<b>Pump Length</b>	39" (1000 mm) or 47" (1200 mm)
<b>Hose</b>	1,8 m, I.D. 1" (25 mm) AtEx Hose
<b>Dispensing Nozzle</b>	1" (25 mm), PVDF (Viton® or EPDM o-ring)
<b>Flow Meter</b>	Digital / PVDF
<b>Barrel Adapter</b>	Polypropylene
<b>Storage Bracket</b>	Stainless Steel
<b>Max. Flow Rate</b>	61 LPM <i>based on water</i>
<b>Max. Viscosity</b>	300 cps (mPas)
<b>Max. Temperature</b>	80 °C

Part Number	Voltage	Pump Length
9590	220-240V	39" (1000 mm)
9591	220-240V	47" (1200 mm)

⚠ Warning: Not suitable for pumping flammable or combustible liquids.



## Pump Package 6 | Mineral acids

Engineered to transfer mineral acids and suitable chemicals. Applications include: Nitric Acid (<60%) and Citric Acid.

<b>Motor Type</b>	SPE-950V (Variable Speed Drive)
<b>Pump Assembly</b>	Stainless Steel 316 (ATEX)
<b>Pump Length</b>	39" (1000 mm) or 47" (1200 mm)
<b>Hose</b>	1,8 m, I.D. 1" (25 mm) PVC
<b>Dispensing Nozzle</b>	1" (25 mm), SS316
<b>Barrel Adapter</b>	Stainless Steel
<b>Storage Bracket</b>	Stainless Steel
<b>Max. Flow Rate</b>	89 LPM <i>based on water</i>
<b>Max. Viscosity</b>	1500 cps (mPas)
<b>Max. Temperature</b>	80 °C

Part Number	Voltage	Pump Length
9570	220-240V	39" (1000 mm)
9571	220-240V	47" (1200 mm)

### Pump Package 6 with ALU Nozzle

Part Number	Voltage	Pump Length
9572	220-240V	39" (1000 mm)
9573	220-240V	47" (1200 mm)

⚠ Warning: Not suitable for pumping flammable or combustible liquids.



## Pump Package 7 | Non-corrosive liquids and light oils

Standard Pumps Aluminum Pump Package is designed to transfer non-corrosive liquids such as machining lubricants, hydraulic fluid, motor oil, anti-freeze and light oils from barrels and tote tanks. This package has been engineered to be light weight and portable while still maintaining a robust quality and high rate of flow.

<b>Motor Type</b>	SPE-950V (Variable Speed Drive)
<b>Pump Assembly</b>	Aluminium (ATEX)
<b>Pump Length</b>	39" (1000 mm) or 47" (1200 mm)
<b>Hose</b>	1,8 m I.D. 3/4" x O.D 1" (25 mm) PVC
<b>Dispensing Nozzle</b>	1" (25 mm), Aluminium
<b>Barrel Adapter</b>	Stainless Steel depending on liquid
<b>Storage Bracket</b>	Stainless Steel
<b>Max. Flow Rate</b>	89 LPM <i>based on water</i>
<b>Max. Viscosity</b>	1500 cps (mPas)
<b>Max. Temperature</b>	80 °C

Part Number	Voltage	Pump Length
9560	220-240V	39" (1000 mm)
9561	220-240V	47" (1200 mm)

⚠ Warning: Not suitable for pumping flammable or combustible liquids.

# APPLICATIONS



**Drums & Barrels**



**Laboratory**



**Large Storage Vessels**



**IBCs**



## SPE-12V/24V Series



Part Number	Enclosure	Power	Watt	V.S.D	Gross WT
SPE-12VA	Open Drip Proof (IP44)	12V DC PLUG	150	No	2,3 kg
SPE-24VA	Open Drip Proof (IP44)	24V DC PLUG	150	No	2,3 kg

Battery plugs: Only on request



Note: V.S.D. = Variable Speed Drive.



## SPE-250 B



Part Number	Enclosure	Power	Watt	V.S.D	Gross WT
SPE-250B	Open Drip Proof (IP44)	230V/50-60Hz	250	No	2,3 kg
SPE-001	Cartridge brushes	Spare Part			

Note: V.S.D. = Variable Speed Drive.

Warning: Not suitable for pumping flammable or combustible liquids.



## SPE-450 Series



Part Number	Enclosure	Power	Watt	V.S.D	Gross WT
SPE-450	TEFC (IP54)	230V/50-60Hz	450	No	3,3 kg
SPE-450V	TEFC (IP54)	230V/50-60Hz	450	Yes	3,3 kg

Note: V.S.D. = Variable Speed Drive.

Warning: Not suitable for pumping flammable or combustible liquids.



## SPE-650 Series



Part Number	Enclosure	Power	Watt	V.S.D	Gross WT
SPE-650	Open Drip Proof (IP54)	230-240V/50-60Hz	650	No	3,3 kg
SPE-650V	Open Drip Proof (IP54)	230-240V/50-60Hz	650	Yes	3,3 kg

Note: V.S.D. = Variable Speed Drive.

Warning: Not suitable for pumping flammable or combustible liquids.



## SPE-950 Series



Part Number	Enclosure	Power	Watt	V.S.D	Gross WT
SPE-950	TEFC (IP54)	230-240V/50-60Hz	950	No	3,3kg
SPE-950V	TEFC (IP54)	230-240V/50-60Hz	950	Yes	3,3 kg

Note: V.S.D. = Variable Speed Drive.

Warning: Not suitable for pumping flammable or combustible liquids.



## SP-280P-2 Series



Part Number	Enclosure	Power	Watt	V.S.D	LVR	Gross WT
SP-280P-2	TEFC (IP44)	230-240V/50-60Hz	825	No	Yes	4,0 kg
SP-280P-2-V	TEFC (IP44)	230-240V/50-60Hz	825	Yes	Yes	4,0 kg

Note: V.S.D. = Variable Speed Drive  
Note: LVR= Low Voltage Release.

⚠ Warning: Not suitable for pumping flammable or combustible liquids.  
Note: Pump Motor available in 110/120V on request.



## SP-ENC-2 Series



Part Number	Enclosure	Power	Watt	V.S.D	LVR	Gross WT
SP-ENC-2	TEFC (IP54)	230-240V/50-60Hz	825	No	Yes	5,7 kg
SP-ENC-2-V	TEFC (IP54)	230-240V/50-60Hz	825	Yes	Yes	5,7 kg

Note: V.S.D. = Variable Speed Drive  
Note: LVR= Low Voltage Release.

⚠ Warning: Not suitable for pumping flammable or combustible liquids.  
Note: Pump Motor available in 110/120V on request.



## SP-440EX



Part Number	Enclosure	Power	Watt	V.S.D	LVR	Gross WT
SP-440EX	Explosion Proof	220-240V/1/50-60Hz	1000	Yes	Yes	7,7 kg

RPM (min-max) 1000-12.000.  
Atex II 2G Ex d ib IIB T5 Gb

Note: V.S.D. = Variable Speed Drive  
Note: LVR = Low Voltage Release

Note: Explosion proof motor regulations require that motors shall be returned to the manufacturer for repair.

⚠ See warning at bottom of page.  
Note: Pump Motor available in 110/120V on request.



## SP-A2 Series



Part Number	Consumption	Max. Inlet Pressure	Output	Gross WT
SP-A2	28 CFM @ 90 psi 13.2 L/sec @ 6,2 bar	100 psi 6,8 bar	¾ HP 560W	1,5 kg
SP-A2P (trigger lock)	28 CFM @ 90 psi 13.2 L/sec @ 6,2 bar	100 psi 6,8 bar	¾ HP 560W	1,5kg

⚠ Warning: Not suitable for pumping flammable or combustible liquids.

Warning: Pumping of flammables or combustible liquids can generate a static electric discharge, causing fire or explosion resulting in injury or death. Read and understand operating instructions before starting this unit. Follow all federal, state and local safety codes including NFPA 30 - NFPA77. Prior to connecting to air supply, install bond and ground wires and check continuity of each wire. A meter reading of one ohm or less is required for safe liquid transfer. Use only metallic drum, receiving vessel and metallic pump when pumping flammables. Air motors are not recognized under any current Underwriter's Laboratory listing program. Consult a qualified engineer for suitability for use in a hazardous area or on flammables.

# SP-280 Series Motor Spare Parts

SP-280-2(-V)

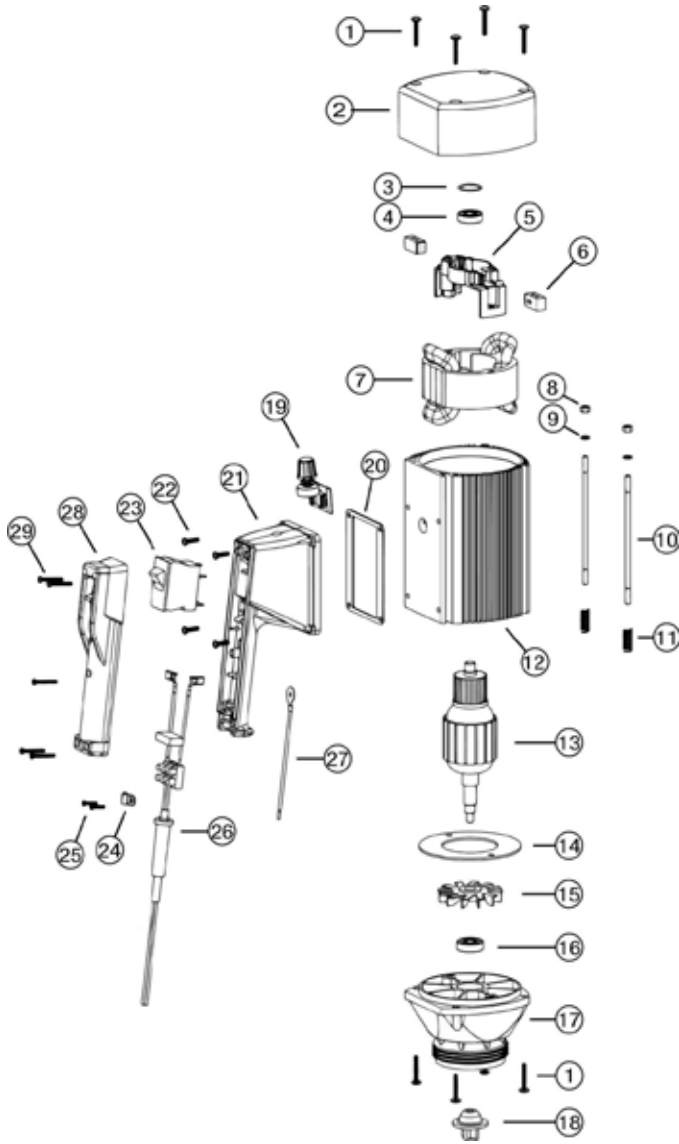

Ref #	Description	Part number	Qty
1	Screw, Motor Cover/Lower Housing	8130P	8
2	Motor Cover	8000	1
3	Wave Washer	8125	1
4	Bearing, Upper	8331	1
5	Brush Holder	8508	1
6	Carbon Brushes, 110/220V	8509*	2
7	Stator		1
	110V	8503	
	220V	8702	
8	Hexagon Nut	8448	2
9	Lock Washer	8071	2
10	Rod Connector	8506	2
11	Pressure Spring	8507	2
12	Motor Housing	8510P	1
13	Armature		1
	110V	8502	
	220V	8701	
14	Guide Disc	8504	1
15	Fan	8512	1
16	Bearing, Lower	8126	1
17	Lower Housing	8100	1
18	Motor Coupling	8333*	1
19	Speed Potentiometer		1
	110V	9803	
	220V	9804	
20	Gasket		1
	110V	8167	
	220V	8167LVR	
21	Switch Housing		1
	Fixed Speed	8001	
	Variable Speed	8010	
22	Screw, Switch Housing		4
	110V	8131	
	220V	8131LVR	
23	Overload Switch		1
	110V	8611	
	220V (w/ Low Voltage Release)	8704LVR	
	220V (w/o Low Voltage Release)	8704	
24	Cable Clamp	8001-1	
25	Screw, Cable Clamp	8001-2	
26	Power Cord		1
	110V	8360-KIT	
	220V	8705-KIT	
27	Earthing Lead	8183	1
28	Switch Cover	8002	1
29	Screw, Switch Cover	8221	5
N/A	Repair Kit* (Includes Items 6 & 18)		1
	110V - 220V	9055	

# SP-ENC Series Motor Spare Parts

SP-ENC-2(-V)

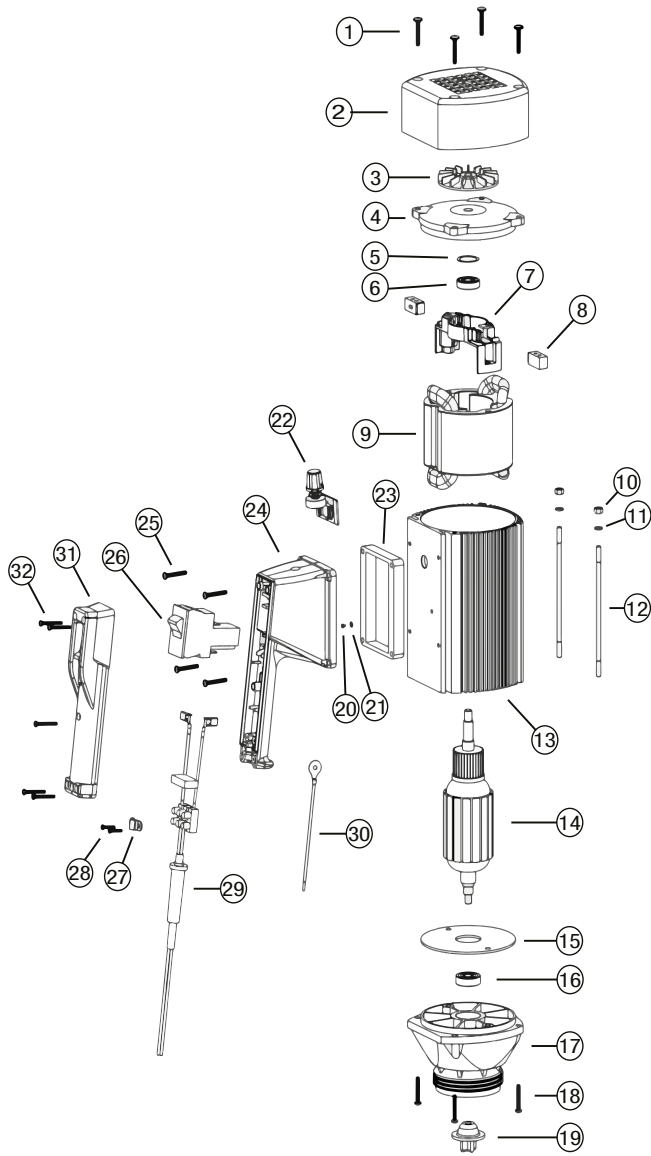

Ref #	Description	Part Number	Qty
1	Screw, Motor Cover	3130	4
2	Motor Cover	3000	1
3	Fan	3512	1
4	Bearing Cover	3511	1
5	Wave Washer	8125	1
6	Bearing, Upper	8331	1
7	Brush Holder	8508	1
8	Carbon Brushes, 110/220V	8509*	2
9	Stator		1
	220V	3702	
10	Hexagon Nut	8448	2
11	Lock Washer	8071	2
12	Rod Connector	3703	2
13	Motor Housing	3510	1
14	Armature		1
	220V	3701	
15	Guide Disc	3504	1
16	Bearing, Lower	8126	1
17	Lower Housing	8100	1
18	Screw, Lower Housing	8130	4
19	Motor Coupling	8333*	1
20	Ground Screw	8162	1
21	Star Washer	8511	1
22	Speed Potentiometer		1
	220V	9804	
23	Gasket		1
	220V	8167LVR	
24	Switch Housing		1
	Fixed Speed	8001	
	Variable Speed	8010	
25	Screw, Switch Housing		4
	220V	8131LVR	
26	Overload Switch		1
	220V (w/ Low Voltage release)	8704LVR	
27	Cable Clamp	8001-1	1
28	Screw, Cable Clamp	8001-2	2
29	Power Cord		1
	110V	8360-KIT	
	220V	8705-KIT	
30	Earthing Lead	8183	1
31	Switch Cover	8002	1
32	Screw, Switch Cover	8221	5
N/A	Repair Kit* (Includes Items 8 & 19)		1
	110V - 220V	9055	



# SP-A2 (P) Air Motor Spare Parts

SP-A2(P)

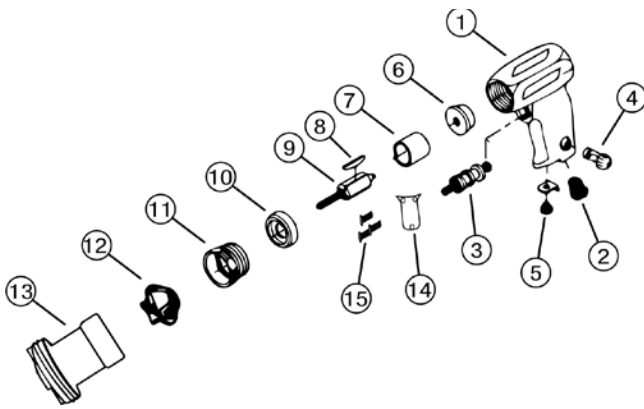

Ref. # Description Part Number

Ref. #	Description	Part Number
1	Housing Assembly	317-A-A40
2	Inlet Bushing	317A-3B
3	Trigger Assembly	317A-A93
4	Regulator Assembly	317A-A249
5	Muffler Kit	317A-AMK1
6	Rear End Plate Assembly	317A-A12
7	Cylinder	317-A3
8	Vanes (4 required)	317A-42-4
9	Rotor	317A-53
10	Front End Plate Assembly	317A-A11
11	Motor Lock Nut	317A-27
12	Motor Coupling	8333
13	Adaptor	3170
14	Trigger Plate (SP-A2P Only)	3176
15	Trigger Plate Screws (3 Required) (SP-A2P Only)	3177



# Motor & Tube Assembly Details

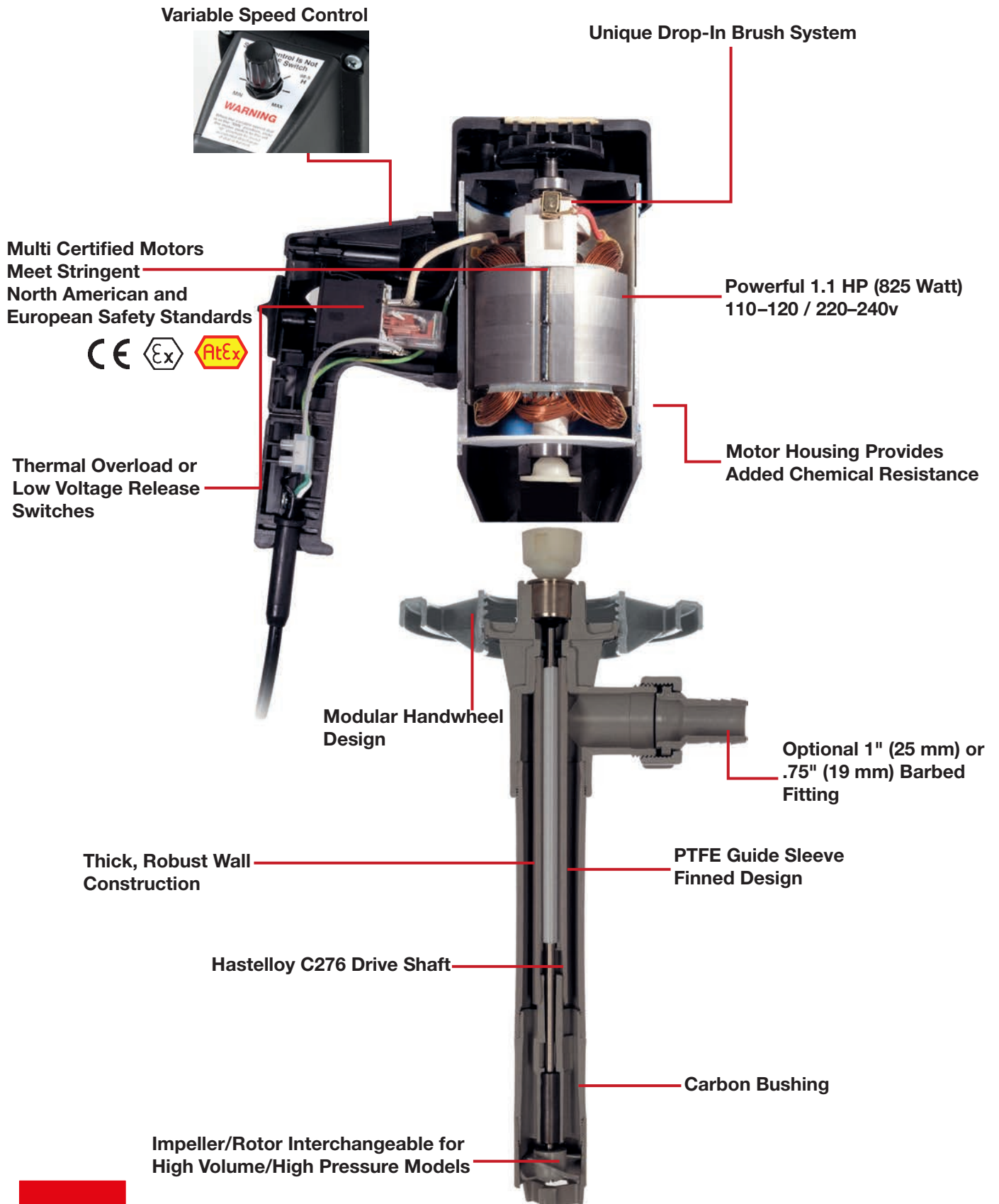

# Pump Tubes – Polypropylene Series

**STANDARD's Polypropylene** pump tube is engineered for transferring a variety of corrosive liquids. Robust Polypropylene ensures chemical resistance against light to aggressive chemicals.

## Common Applications

- Acetic Acid
- Alkalis
- Ferric Chloride
- Hydrochloric (20%)
- Nitric Acid (20%)
- Sulfuric Acid

## Technical Specifications

<b>Wetted Parts</b>	Polypropylene, Carbon, Hastelloy
<b>Max. Viscosity</b>	1500 cps (mPas) (SP-280P, SP-ENC, SPE-950) 1000 cps (mPas) (SP-440EX) 750 cps (mPas) (SPE-450, SPE-650, SP-A2) 200 cps (mPas) (SPE-250B), 100 cps (mPas) (SPE-12/24V)
<b>Discharge Options</b>	1" (25 mm), 3/4" (19 mm) Hose Barb
<b>Pump Design</b>	Seal-less / Centrifugal
<b>Max. Specific Gravity</b>	1.8 (with 825 watt or 950 watt motor)
<b>Max. Temperature</b>	55 °C

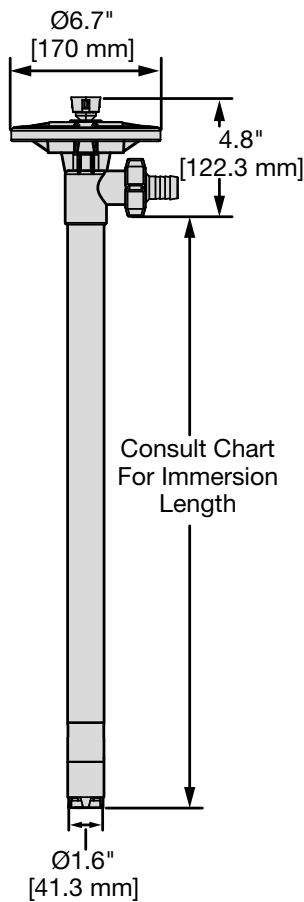

Part Number	Assembly	Immersion Length	Shaft	Impeller	Gross WT
SP-PP-27	Polypropylene	27" (700 mm)	Hastelloy	High Volume	2,7 kg
SP-PP-39	Polypropylene	39" (1000 mm)	Hastelloy	High Volume	2,9 kg
SP-PP-47	Polypropylene	47" (1200 mm)	Hastelloy	High Volume	3,4 kg
SP-PP-50	Polypropylene	50" (1270 mm)	Hastelloy	High Volume	3,6 kg
SP-PP-60	Polypropylene	60" (1500 mm)	Hastelloy	High Volume	5,0 kg
SP-PP-72	Polypropylene	72" (1800 mm)	Hastelloy	High Volume	7,0 kg
SP-PP-HH-27	Polypropylene	27" (700 mm)	Hastelloy	High Pressure	2,7 kg
SP-PP-HH-39	Polypropylene	39" (1000 mm)	Hastelloy	High Pressure	2,9 kg
SP-PP-HH-47	Polypropylene	47" (1200 mm)	Hastelloy	High Pressure	3,4 kg
SP-PP-HH-50	Polypropylene	50" (1270 mm)	Hastelloy	High Pressure	3,6 kg
SP-PP-HH-60	Polypropylene	60" (1500 mm)	Hastelloy	High Pressure	5,0 kg
SP-PP-HH-72	Polypropylene	72" (1800 mm)	Hastelloy	High Pressure	7,0 kg

# Pump Tubes – SP-PP Series Spare Parts

## SP-PP Spare Parts

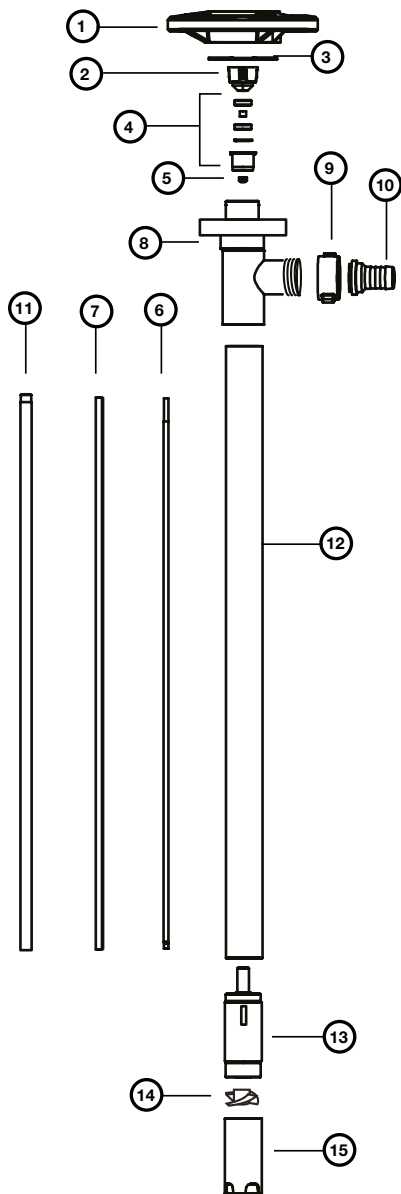

Ref #	Description	Part Number	Qty
1	Hand Wheel, Polypropylene	1842	1
2*	Pump Coupling, Nylon	1004	1
3	Snap Ring, Steel	1508	1
4*	Bearing Unit, Assembly	1038	1
5	V-Seal, Viton	1000	1
6	Drive Shaft, Hastelloy C-276		1
	27" (700 mm)	1543	
	39" (1000 mm)	1544	
	47" (1200 mm)	1545	
	50" (1270 mm)	1549	
	60" (1500 mm)	1546	
	72" (1800 mm)	1547	
7	Guide Sleeve, PTFE		1
	27" (700 mm)	1516	
	39" (1000 mm), 47" (1200 mm), 50" (1270 mm)	1514	
	60" (1500 mm), 72" (1800 mm)	1661	
8	Discharge Housing, Polypropylene	1028	1
9	Wing Nut, Polypropylene	1106	1
10	Hose Barb, Polypropylene		1
	.75" (19 mm)	1051	
	1" (25 mm)	1082	
11	Inner Tube, Polypropylene		1
	27" (700 mm)	1600	
	39" (1000 mm)	1601	
	47" (1200 mm)	1602	
	50" (1270 mm)	1623	
	60" (1500 mm)	1615	
	72" (1800 mm)	1616	
12	Outer Tube, Polypropylene		1
	27" (700 mm)	1604	
	39" (1000 mm)	1603	
	47" (1200 mm)	1605	
	50" (1270 mm)	1624	
	60" (1500 mm)	1617	
	72" (1800 mm)	1618	
13*	Pump Housing, Polypropylene (Includes Carbon Bushing)	1524	1
14*	Rotor/Impeller		1
	High Volume Rotor, Polypropylene	1608	
	High Pressure Impeller, PTFE	4608HH	
15*	Pump Foot		1
	High Volume, Polypropylene	1609	
	High Pressure, Polypropylene & PTFE	1609HH	
	Repair Kit* (Includes 2, 4, 13, 14 & 15)	9050	1

⚠ Warning: Not suitable for pumping flammable or combustible liquids or for use in a hazardous duty environment.

# Pump Tubes – Polypropylene Series with SS316 Shaft

**STANDARD's Polypropylene** pump tube with SS316 shaft is engineered for transferring a variety of corrosive liquids. Robust Polypropylene and SS316 shaft ensures chemical resistance against light chemicals.

## Common Applications

- Aluminium Hydroxide
- Citric Acid
- Etyhylene Glycol
- Ferric Nitrate
- Glycerin
- Sodium Sulfate

## Technical Specifications

<b>Wetted Parts</b>	Polypropylene, Carbon, SS316
<b>Max. Viscosity</b>	1500 cps (mPas) (SP-280P, SP-ENC, SPE-950) 1000 cps (mPas) (SP-440EX) 750 cps (mPas) (SPE-450, SPE-650, SP-A2) 200 cps (mPas) (SPE-250B) 100 cps (mPas) (SPE-12/24V)
<b>Discharge Options</b>	1" (25 mm), ¾" (19 mm) Hose Barb
<b>Pump Design</b>	Seal-less / Centrifugal
<b>Max. Specific Gravity</b>	1.8 (with 825 watt or 950 watt motor)
<b>Max. Temperature</b>	55 °C

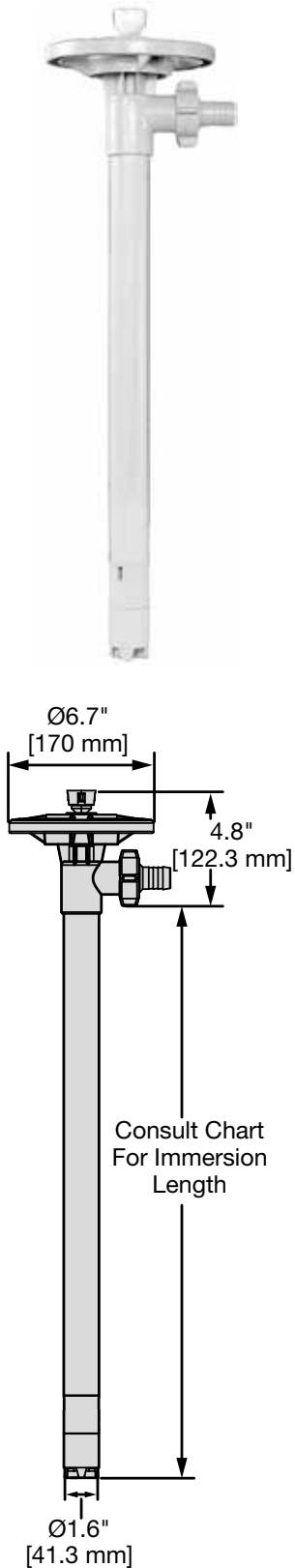

Part Number	Assembly	Immersion Length	Shaft	Impeller	Gross WT
SP-PPS-27	Polypropylene	27" (700 mm)	Stainless Steel	High Volume	2,7 kg
SP-PPS-39	Polypropylene	39" (1000 mm)	Stainless Steel	High Volume	2,9 kg
SP-PPS-47	Polypropylene	47" (1200 mm)	Stainless Steel	High Volume	3,4 kg
SP-PPS-50	Polypropylene	50" (1270 mm)	Stainless Steel	High Volume	3,6 kg
SP-PPS-60	Polypropylene	60" (1500 mm)	Stainless Steel	High Volume	5,0 kg
SP-PPS-72	Polypropylene	72" (1800 mm)	Stainless Steel	High Volume	7,0 kg
SP-PPS-HH-27	Polypropylene	27" (700 mm)	Stainless Steel	High Pressure	2,7 kg
SP-PPS-HH-39	Polypropylene	39" (1000 mm)	Stainless Steel	High Pressure	2,9 kg
SP-PPS-HH-47	Polypropylene	47" (1200 mm)	Stainless Steel	High Pressure	3,4 kg
SP-PPS-HH-50	Polypropylene	50" (1270 mm)	Stainless Steel	High Pressure	3,6 kg
SP-PPS-HH-60	Polypropylene	60" (1500 mm)	Stainless Steel	High Pressure	5,0 kg
SP-PPS-HH-72	Polypropylene	72" (1800 mm)	Stainless Steel	High Pressure	7,0 kg

# Pump Tubes – SP-PPS Series Spare Parts

SP-PPS Spare Parts		Ref #	Description	Part Number	Qty
	1	Hand Wheel	1842	1	
	2*	Pump Coupling	1004	1	
	3	Snap Ring	1508	1	
	4*	Bearing Unit, Assembly	1038	1	
	5	V-Seal, Viton	1000	1	
	6	Drive Shaft		1	
		27" (700 mm)	2027		
		39" (1000 mm)	2028		
		47" (1200 mm)	2029		
		60" (1500 mm)	2709	Discontinued	
		72" (1800 mm)	2033	Discontinued	
	7	Guide Sleeve, PTFE		1	
		27" (700 mm)	1516		
		39" (1000 mm), 47" (1200 mm), 50" (1270 mm)	1514		
		60" (1500 mm), 72" (1800 mm)	1661		
8	Discharge Housing	1028	1		
9	Wing Nut	1106	1		
10	Hose Barb		1		
	.75" (19 mm)	1051			
	1" (25 mm)	1082			
11	Inner Tube		1		
	27" (700 mm)	1600			
	39" (1000 mm)	1601			
	47" (1200 mm)	1602			
	50" (1270 mm)	1623			
	60" (1500 mm)	1615			
	72" (1800 mm)	1616			
12	Outer Tube		1		
	27" (700 mm)	1604			
	39" (1000 mm)	1603			
	47" (1200 mm)	1605			
	50" (1270 mm)	1624			
	60" (1500 mm)	1617			
	72" (1800 mm)	1618			
13*	Pump Housing (Includes Carbon Bushing)	1524	1		
14*	Rotor/Impeller		1		
	High Volume Rotor	1608			
	High Pressure Impeller	4608HH			
15*	Pump Foot		1		
	High Volume	1609			
	High Pressure	1609HH			
	Repair Kit* (Includes 2, 5 (4), 13, 14 & 15)	9050	1		

⚠ Warning: Not suitable for pumping flammable or combustible liquids or for use in a hazardous duty environment.

# Pump Tubes – High Temperature Polypropylene Series



**STANDARD's High Temperature Polypropylene (PHT)** pump tube is engineered for transferring high temperature corrosive liquids. Robust Polypropylene ensures chemical resistance and excellent heat deflection properties against light to mildly aggressive chemicals.

## Common Applications

- Acetic Acid
- Alkalies
- Ferric Chloride
- Hydrochloric (20%)
- Nitric Acid (20%)
- Sulfuric Acid

## Technical Specifications

<b>Wetted Parts</b>	Polypropylene, Carbon, Hastelloy
<b>Max. Viscosity</b>	1500 cps (mPas) (SP-280P, SP-ENC, SPE-950) 1000 cps (mPas) (SP-440EX) 750 cps (mPas) (SPE-450, SPE-650, SP-A2) 200 cps (mPas) (SPE-250B) 100 cps (mPas) (SPE-12/24V)
<b>Discharge Options</b>	1" (25 mm), 3/4" (19 mm) Hose Barb
<b>Pump Design</b>	Seal-less / Centrifugal
<b>Max. Specific Gravity</b>	1.8 (with 825 watt or 950 watt motor)
<b>Max. Temperature</b>	80 °C

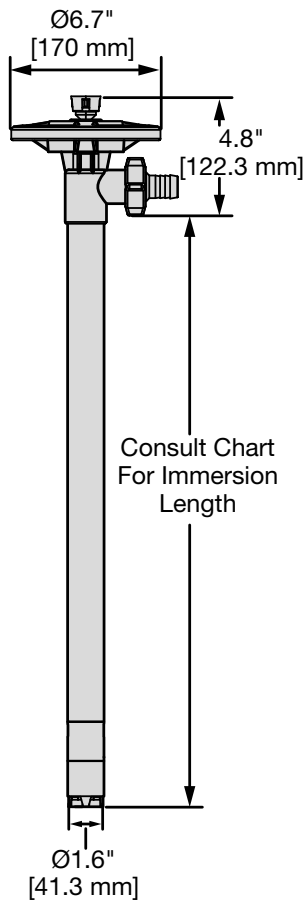

Part Number	Assembly	Immersion Length	Shaft	Impeller	Gross WT
SP-PHT-27	Polypropylene	27" (700 mm)	Hastelloy	High Volume	2,0 kg
SP-PHT-HH-27	Polypropylene	27" (700 mm)	Hastelloy	High Pressure	2,0 kg

Few spare parts available, on request

# Performance Curves for Centrifugal Pumps

## SP-PP, SP-PPS, SP-CPVC & SP-PVDF

High Volume Pumps:

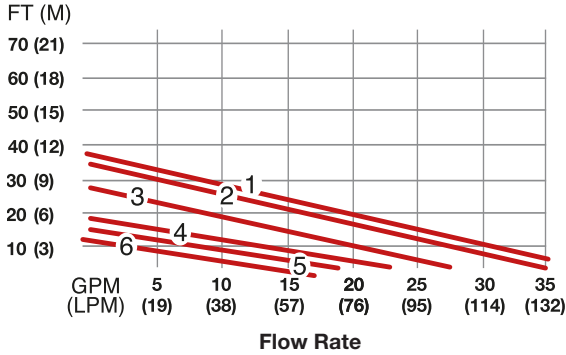

**Motor:**

- 1 SPE-950
- 2 SP-280P, SP-ENC
- 3 SPE-450, SP-A2
- 4 SPE-250B
- 5 SPE-24V
- 6 SPE-12V

High Pressure Pumps:

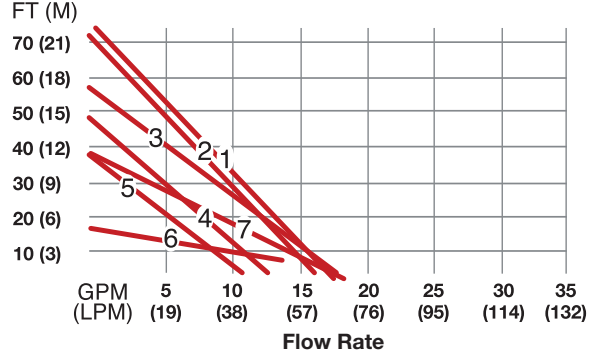

**Motor:**

- 1 SPE-950
- 2 SP-280P, SP-ENC
- 3 SPE-450, SP-A2
- 4 SPE-250B
- 5 SP-A1
- 6 SPE-12V
- 7 SPE-24V

## SP-6600/6700 Series, SP-7600/7700 Series



High Volume Pumps:

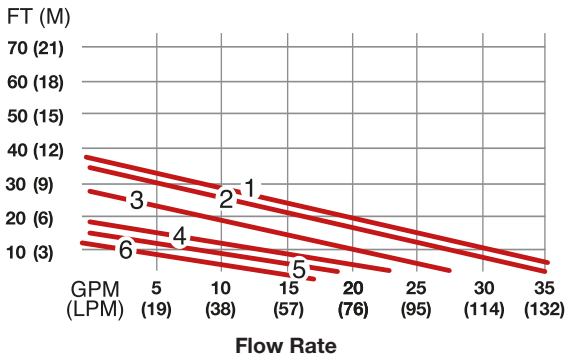

**Motor:**

- 1 SPE-950
- 2 SP-280P, SP-ENC, SP-440EX
- 3 SPE-450, SP-A2, SP-420EX
- 4 SPE-250B
- 5 SPE-24V
- 6 SPE-12V

High Pressure Pumps:

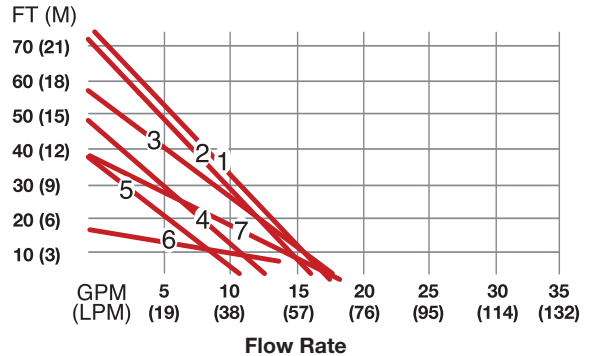

**Motor:**

- 1 SPE-950
- 2 SP-280P, SP-ENC, SP-440EX
- 3 SPE-450, SP-A2, SP-420EX
- 4 SPE-250B
- 5 SP-A1
- 6 SPE-12V
- 7 SPE-24V

Performance measured by pumping clean water at 20° C.

**Warning:** When pumping flammable or combustible liquids pump tube must be used in conjunction with an explosion proof motor.

\*Note: Max. Specific Gravity is 1.8 when used in conjunction with 825 watt motor or 950 watt motor.



# Pump Tubes – CPVC Series

**STANDARD's CPVC** pump tube is engineered for transferring corrosive chemicals commonly used in the Water Treatment Industry. Robust CPVC offers excellent durability and chemical resistance.

## Common Applications

- Calcium Chloride
- Calcium Hydroxide
- Chlorinated Water
- Potassium Hydroxide
- Sodium Bromide
- Sodium Hypochlorite

## Technical Specifications

<b>Wetted Parts</b>	CPVC, Carbon, Hastelloy
<b>Max. Viscosity</b>	1500 cps (mPas) (SP-280P, SP-ENC, SPE-950) 1000 cps (mPas) (SP-440EX) 750 cps (mPas) (SPE-450, SPE-650, SP-A2) 200 cps (mPas) (SPE-250B) 100 cps (mPas) (SPE-12/24V)
<b>Discharge Options</b>	1" (25 mm), ¾" (19 mm) Hose Barb
<b>Pump Design</b>	Seal-less / Centrifugal
<b>Max. Specific Gravity</b>	1.8 (with 825 watt or 950 watt motor)
<b>Max. Temperature</b>	88 °C

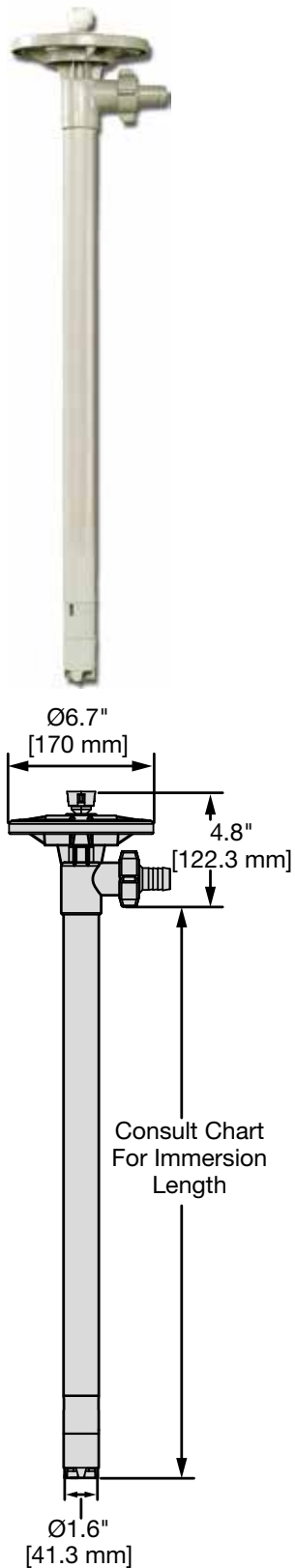

Part Number	Assembly	Immersion Length	Shaft	Impeller	Gross WT
SP-CPVC-27	CPVC	27" (700 mm)	Hastelloy	High Volume	2,7 kg
SP-CPVC-39	CPVC	39" (1000 mm)	Hastelloy	High Volume	3,4 kg
SP-CPVC-47	CPVC	47" (1200 mm)	Hastelloy	High Volume	3,9 kg
SP-CPVC-50	CPVC	50" (1270 mm)	Hastelloy	High Volume	5,5 kg
SP-CPVC-60	CPVC	60" (1500 mm)	Hastelloy	High Volume	5,5 kg
SP-CPVC-72	CPVC	72" (1800 mm)	Hastelloy	High Volume	6,5 kg
SP-CPVC-HH-27	CPVC	27" (700 mm)	Hastelloy	High Pressure	2,7 kg
SP-CPVC-HH-39	CPVC	39" (1000 mm)	Hastelloy	High Pressure	3,4 kg
SP-CPVC-HH-47	CPVC	47" (1200 mm)	Hastelloy	High Pressure	3,9 kg
SP-CPVC-HH-50	CPVC	50" (1270 mm)	Hastelloy	High Pressure	5,5 kg
SP-CPVC-HH-60	CPVC	60" (1500 mm)	Hastelloy	High Pressure	5,5 kg
SP-CPVC-HH-72	CPVC	72" (1800 mm)	Hastelloy	High Pressure	6,5 kg



# Pump Tubes – CPVC Series Spare Parts

CPVC Spare Parts		Ref #	Description	Part Number	Qty
	1	Hand Wheel, Polypropylene	1842	1	
	2*	Pump Coupling, Nylon	1004	1	
	3	Snap Ring, Steel	1508	1	
	4*	Bearing Unit, Assembly	1038	1	
	5	V-Seal, PTFE	4000	1	
	6	Drive Shaft, Hastelloy C-276		1	
		27" (700 mm)	1543		
		39" (1000 mm)	1544		
		47" (1200 mm)	1545		
		50" (1270 mm)	1549		
		60" (1500 mm)	1546		
		72" (1800 mm)	1547		
	7	Guide Sleeve, PTFE		1	
		27" (700 mm)	1516		
		39" (1000 mm), 47" (1200 mm), 50" (1270 mm)	1514		
	60" (1500 mm), 72" (1800 mm)	1661			
8	Discharge Housing, CPVC	5028	1		
9	Wing Nut, CPVC	5106	1		
10	Hose Barb, CPVC		1		
	.75" (19 mm)	5051			
	1" (25 mm)	5082			
11	Inner Tube, CPVC		1		
	27" (700 mm)	5600			
	39" (1000 mm)	5601			
	47" (1200 mm)	5602			
	50" (1270 mm)	5623			
	60" (1500 mm)	5615			
	72" (1800 mm)	5616			
12	Outer Tube, CPVC		1		
	27" (700 mm)	5604			
	39" (1000 mm)	5603			
	47" (1200 mm)	5605			
	50" (1270 mm)	5624			
	60" (1500 mm)	5617			
	72" (1800 mm)	5618			
13*	Pump Housing, Polypropylene (Includes Carbon Bushing)	5524	1		
14*	Rotor/Impeller		1		
	High Volume Rotor, Polypropylene	5608			
	High Pressure Impeller, PTFE	4608HH			
15*	Pump Foot		1		
	High Volume, CPVC	5609			
	High Pressure, CPVC	5609HH			
	Repair Kit* (Includes 2, 4, 13, 14 & 15)	9052	1		

**⚠ Warning:** Not suitable for pumping flammable or combustible liquids or for use in a hazardous duty environment.

# Pump Tubes – PVDF (Kynar®) Series

**STANDARD's PVDF** pump tube is engineered for transferring highly concentrated and aggressive liquids. Robust PVDF offers excellent durability and chemical resistance.

## Common Applications

- Concentrated Nitric Acid
- Hydrofluoric Acid
- Propionic Acid
- Searic Acid
- Sodium Hypochlorite
- Sulfuric Acid-66 Baume

## Technical Specifications

<b>Wetted Parts</b>	PVDF, Carbon, Hastelloy
<b>Max. Viscosity</b>	1500 cps (mPas) (SP-280P, SP-ENC, SPE-950) 1000 cps (mPas) (SP-440EX) 750 cps (mPas) (SPE-450, SPE-650, SP-A2) 200 cps (mPas) (SPE-250B) 100 cps (mPas) (SPE-12/24V)
<b>Discharge Options</b>	1" (25 mm), ¾" (19 mm) Hose Barb
<b>Pump Design</b>	Seal-less / Centrifugal
<b>Max. Specific Gravity</b>	1.8 (with 825 watt or 950 watt motor)
<b>Max. Temperature</b>	80 °C

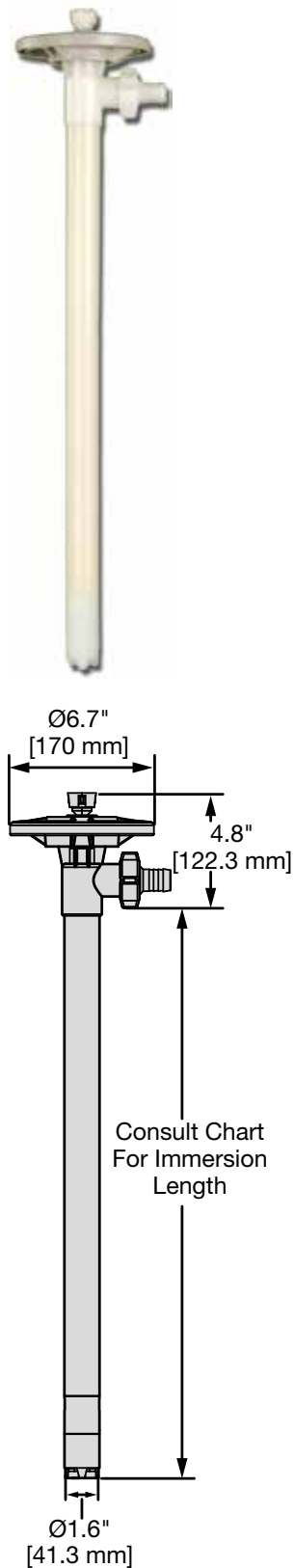

Part Number	Assembly	Immersion Length	Shaft	Impeller	Gross WT
SP-PVDF-27	PVDF	27" (700 mm)	Hastelloy	High Volume	2,7 kg
SP-PVDF-39	PVDF	39" (1000 mm)	Hastelloy	High Volume	3,6 kg
SP-PVDF-47	PVDF	47" (1200 mm)	Hastelloy	High Volume	5,0 kg
SP-PVDF-50	PVDF	50" (1270 mm)	Hastelloy	High Volume	5,0 kg
SP-PVDF-60	PVDF	60" (1500 mm)	Hastelloy	High Volume	7,0 kg
SP-PVDF-72	PVDF	72" (1800 mm)	Hastelloy	High Volume	7,8 kg
SP-PVDF-HH-27	PVDF	27" (700 mm)	Hastelloy	High Pressure	2,7 kg
SP-PVDF-HH-39	PVDF	39" (1000 mm)	Hastelloy	High Pressure	3,6 kg
SP-PVDF-HH-47	PVDF	47" (1200 mm)	Hastelloy	High Pressure	5,0 kg
SP-PVDF-HH-50	PVDF	50" (1270 mm)	Hastelloy	High Pressure	5,0 kg
SP-PVDF-HH-60	PVDF	60" (1500 mm)	Hastelloy	High Pressure	7,0 kg
SP-PVDF-HH-72	PVDF	72" (1800 mm)	Hastelloy	High Pressure	7,8 kg

# Pump Tubes – PVDF Series Spare Parts

PVDF Spare Parts		Ref #	Description	Part Number	Qty
	1	Hand Wheel, Polypropylene	1842	1	
	2*	Pump Coupling, Nylon	1004	1	
	3	Snap Ring, Steel	1508	1	
	4*	Bearing Unit, Assembly	1038	1	
	5	V-Seal, PTFE	4000	1	
	6	Drive Shaft, Hastelloy C-276		1	
		27" (700 mm)	1543		
		39" (1000 mm)	1544		
		47" (1200 mm)	1545		
		50" (1270 mm)	1549		
		60" (1500 mm)	1546		
		72" (1800 mm)	1547		
	7	Guide Sleeve, PTFE		1	
		27" (700 mm)	1516		
		39" (1000 mm), 47" (1200 mm), 50" (1270 mm)	1514		
	60" (1500 mm), 72" (1800 mm)	1661			
8	Discharge Housing, PVDF	4028	1		
9	Wing Nut, PVDF	4106	1		
10	Hose Barb, PVDF		1		
	.75" (19 mm)	4051			
	1" (25 mm)	4082			
11	Inner Tube, PVDF		1		
	27" (700 mm)	4600			
	39" (1000 mm)	4601			
	47" (1200 mm)	4602			
	50" (1270 mm)	4623			
	60" (1500 mm)	4615			
	72" (1800 mm)	4618			
12	Outer Tube, PVDF		1		
	27" (700 mm)	4604			
	39" (1000 mm)	4603			
	47" (1200 mm)	4605			
	50" (1270 mm)	4622			
	60" (1500 mm)	4617			
	72" (1800 mm)	4619			
13*	Pump Housing, PVDF (Includes Carbon Bushing)	4607	1		
14*	Rotor/Impeller		1		
	High Volume Rotor, PVDF	4608			
	High Pressure Impeller, PTFE	4608HH			
15*	Pump Foot		1		
	High Volume, PVDF	4609			
	High Pressure, PVDF & PTFE	4609HH			
	Repair Kit* (Includes 2, 4, 13, 14 & 15)	9051	1		

⚠ Warning: Not suitable for pumping flammable or combustible liquids or for use in a hazardous duty environment.



## Common Applications

- Acetic Acid (80%)
- Sodium Hydroxide (50%)
- Nitric Acid (10%)
- Hydrochloric Acid (100%)
- Sulfuric Acid (80%)
- Ferric Chloride (50%)

## Technical Specifications

<b>Pump Design</b>	Seal-less / Centrifugal
<b>Discharge Option</b>	1/2" (12,7 mm) Hose Barb
<b>Wetted Parts</b>	Polypropylene, Carbon Graphite, Hastelloy C-276 (SP-M-PP)
<b>Motor Drive Options</b>	SPE-12V/24V Series, SPE-250B or SPE-450 Series
<b>Max. Viscosity</b>	250 cps (mPas) (SPE-250B)
<b>Max. Discharge Pressure</b>	6.0 psi (0,41 bar)
<b>Max. Flow Rate</b>	20,8 lpm
<b>Max. Temperature</b>	55 °C
<b>Duty Cycle</b>	Intermittent

Part Number	Assembly	Immersion Length	Shaft
SP-M-PP-20	PP	20" (500 mm)	Hastelloy C-276
SP-M-PP-27	PP	27" (700 mm)	Hastelloy C-276
SP-M-PP-39	PP	39" (1000 mm)	Hastelloy C-276

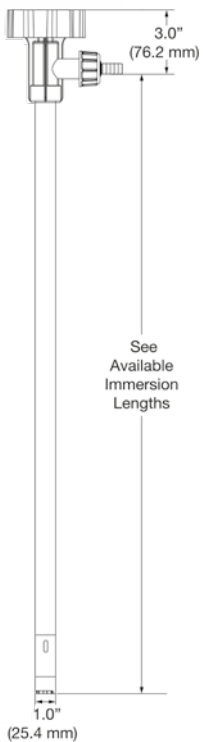

## Motor Drives

Note: Refer to page 6 for motor information



# SP-MINI Series Spare Parts

SP-MINI Spare Parts		Ref. #	Description	Part Number	Qty
	1	Handwheel, Nylon, Mini	1742	1	
	2	Snap Ring, Steel	1508	1	
	3*	Pump Coupling, Nylon	1004	1	
	4*	Bearing Unit	1038	1	
	5*	V-Seal, Viton	1000	1	
	6	Discharge Housing, Polypropylene	1720	1	
	7	Outer Tube, Polypropylene		1	
		20" (500 mm)	1701		
		27" (700 mm)	1703		
		39" (1000 mm)	1705		
	8	Drive Shaft, Hastelloy C-276		1	
		20" (500 mm)	1710		
		27" (700 mm)	1711		
		39" (1000 mm)	1712		
9	Inner Tube, Polypropylene		1		
	20" (500 mm)	1700			
	27" (700 mm)	1702			
	39" (1000 mm)	1702			
	10	Pump Housing, Polypropylene	1723	1	
	11	Rotor, Polypropylene	1724	1	
	12	Pump Foot, Polypropylene	1725	1	
	13	Wing Nut, Polypropylene	1721	1	
	14	Hose Barb, Polypropylene, 1/2" (12,7 mm)	1722	1	

# Pump Tubes – Stainless Steel Series

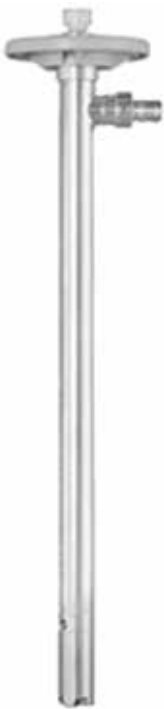

**STANDARD's Stainless** pump tube is engineered for transferring liquids in an ATEX environment. Robust Stainless Steel offers excellent performance, strength and durability.

## Common Applications

- Flammable liquids with a flash point of min. 185°C
- Chemicals according to our resistance guide

## Technical Specifications

<b>Wetted Parts</b>	SS316, Carbon, PTFE
<b>Max. Viscosity</b>	1500 cps (mPas) (SP-280P, SP-ENC, SPE-950) 1000 cps (mPas) (SP-440EX) 750 cps (mPas) (SPE-450, SPE-650, SP-A2) 200 cps (mPas) (SPE-250B) 100 cps (mPas) (SPE-12/24V)
<b>Discharge Options</b>	1" (25 mm) / 3/4" (19 mm) Hose Barb Seal-
<b>Pump Design</b>	less / Centrifugal
<b>Max. Specific Gravity</b>	1.8 (with 825 watt or 950 watt motor)
<b>Max. Temperature</b>	80 °C, AtEx: 40 °C
<b>Directive and Classification</b>	AtEx 2014 / 34 / EU – EX II 2G EX h IIB T4 Gb

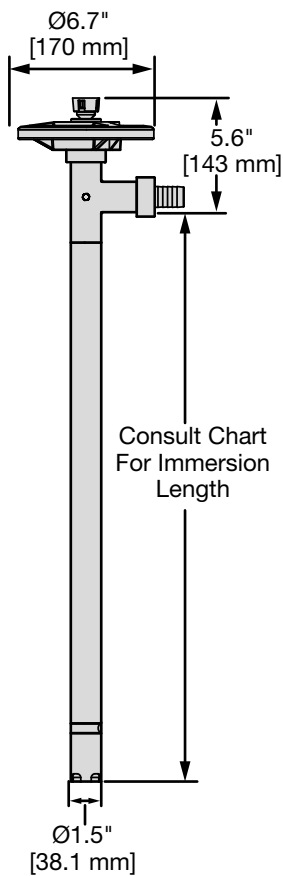

Part Number	Assembly	Immersion Length	Shaft	Impeller	Gross WT
SP-7600-27	Stainless 316	27" (700 mm)	Stainless 316	High Volume	3,6 kg
SP-7600-39	Stainless 316	39" (1000 mm)	Stainless 316	High Volume	5,0 kg
SP-7600-47	Stainless 316	47" (1200 mm)	Stainless 316	High Volume	6,3 kg
SP-7600-60	Stainless 316	60" (1500 mm)	Stainless 316	High Volume	8,0 kg
SP-7600-72	Stainless 316	72" (1800 mm)	Stainless 316	High Volume	9,0 kg
SP-7700-27	Stainless 316	27" (700 mm)	Stainless 316	High Pressure	3,6 kg
SP-7700-39	Stainless 316	39" (1000 mm)	Stainless 316	High Pressure	5,0 kg
SP-7700-47	Stainless 316	47" (1200 mm)	Stainless 316	High Pressure	6,3 kg
SP-7700-60	Stainless 316	60" (1500 mm)	Stainless 316	High Pressure	8,0 kg
SP-7700-72	Stainless 316	72" (1800 mm)	Stainless 316	High Pressure	9,0 kg

# Pump Tubes – SP-7600 & 7700 Series Stainless Steel Spare Parts

SP-7600 & 7700 Series Spare Parts		Ref. #	Description	Part Number	Qty
	1	Hand Wheel, Polypropylene	1842	1	
	2	Snap Ring, Steel	1508	1	
	3*	Pump Coupling, Nylon	1004	1	
	4*	Bearing, Viton Shielded	1038-2	2	
	5*	Bearing Spacer, SS316L	8838-4	1	
	6	V Seal, PTFE	4000	1	
	7	Connection Flange, SS316L	8602	1	
	8	Guide Sleeve, PTFE		1	
		27" (700mm), 39" (1000mm), 47" (1200mm)	7659		
		60" (1500mm), 72" (1800 mm)	7660		
	9	Drive Shaft, SS316L		1	
		27" (700 mm)	8605		
		39" (1000 mm)	8606		
		47" (1200 mm)	8607		
		60" (1500 mm)	8608		
		70" (1800 mm)	8609		
	10*	Seal, PTFE	2195	1	
	11	Knurled Nut, SS316L	7656	1	
12	Hose Barb, SS316L		1		
	.75" (19 mm)	7658			
	1" (25 mm)	7657			
13	Inner/Outer Tube Assembly, SS316L		1		
	27" (700 mm)	7650			
	39" (1000 mm)	7651			
	47" (1200 mm)	7652			
	60" (1500 mm)	7653			
	72" (1800 mm)	7654			
14	O-Ring, Viton	7655	2		
15	Pump Housing, SS316L	7824	1		
16*	Bushing, Carbon Graphite	7606	1		
17*	Rotor/Impeller		1		
	High Volume Rotor, PTFE	7706			
	High Pressure Impeller, PTFE	4608HH			
18	Pump Foot, SS316L		1		
	High Volume	8826			
	High Pressure	8926			
	Ground Wire Set, includes (1) 10 ft. lengths, (2) 6 ft. length, and (1) 1 ft. length.	9003	1		
	Repair Kit* (Includes Items 3, 4, 5, 10, 16 & 17)	7054	1		

**⚠ Warning:** When pumping flammable combustible liquids, this pump must be used in conjunction with an explosion proof motor.

# Pump Tubes – Aluminium Pump Series



**STANDARD's Aluminium** pump tube is engineered for transferring non-corrosive liquids such as Machining Lubricants, hydraulic fluid, motor oil, antifreeze and Light Oils. Robust Aluminium construction offers excellent strength and durability.

## Common Applications

- Anti-Freeze
- Hydraulic Fluid
- Light Machining Oils
- Lubricating Oils
- Motor Oil (up to 30 Wt)

## Technical Specifications

<b>Wetted Parts</b>	Aluminium, Carbon, PTFE & SS316
<b>Max. Viscosity</b>	1500 cps (mPas) (SP-280P, SP-ENC, SPE-950) 1000 cps (mPas) (SP-440EX) 750 cps (mPas) (SPE-450, SPE-650, SP-A2) 200 cps (mPas) (SPE-250B) 100 cps (mPas) (SPE-12/24V)
<b>Discharge Options</b>	1" (25 mm) / 3/4" (19 mm) Hose Barb
<b>Pump Design</b>	Seal-less / Centrifugal
<b>Max. Specific Gravity</b>	1.8 (with 825 watt or 950 watt motor)
<b>Max. Temperature</b>	80 °C, AtEx: 40 °C
<b>Directive and Classification</b>	AtEx 2014 / 34 / EU – EX II 2G EX h IIB T4 Gb

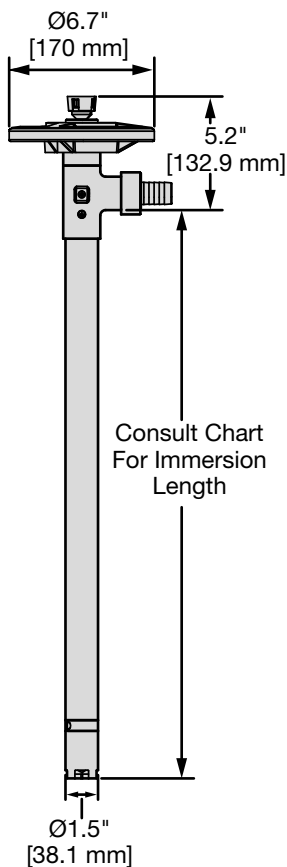

Part Number	Assembly	Immersion Length	Shaft	Impeller	Gross
SP-6600-27	Aluminium	27" (700 mm)	Stainless 316	High Volume	2,7 kg
SP-6600-39	Aluminium	39" (1000 mm)	Stainless 316	High Volume	3,6 kg
SP-6600-47	Aluminium	47" (1200 mm)	Stainless 316	High Volume	4,0 kg
SP-6600-60	Aluminium	60" (1500 mm)	Stainless 316	High Volume	5,4 kg
SP-6600-72	Aluminium	72" (1800 mm)	Stainless 316	High Volume	6,3 kg
SP-6700-27	Aluminium	27" (700 mm)	Stainless 316	High Pressure	2,7 kg
SP-6700-39	Aluminium	39" (1000 mm)	Stainless 316	High Pressure	3,6 kg
SP-6700-47	Aluminium	47" (1200 mm)	Stainless 316	High Pressure	4,0 kg
SP-6700-60	Aluminium	60" (1500 mm)	Stainless 316	High Pressure	5,4 kg
SP-6700-72	Aluminium	72" (1800 mm)	Stainless 316	High Pressure	6,3 kg



# Pump Tubes – SP-6600 & 6700 Series Spare Parts

SP-6600 & 6700 Series Spare Parts		Ref. #	Description	Part Number	Qty
	1	Hand Wheel, Polypropylene	1842	1	
	2	Snap Ring, Steel	1508	1	
	3*	Pump Coupling, Nylon	1004	1	
	4*	Bearing, Viton Shielded	1038-2	2	
	5*	Bearing Spacer, SS316L	8838-4	1	
	6	V-Seal, PTFE	4000	1	
	7	Connection Flange, AL 6061	6650	1	
	8	Drive Shaft, SS316L		1	
		27" (700 mm)	6661		
		39" (1000 mm)	6662		
		47" (1200 mm)	6663		
		60" (1500 mm)	6664		
		72" (1800 mm)	6665		
	9	Guide Sleeve, PTFE		1	
		27" (700mm), 39" (1000mm), 47" (1200mm)	7659		
		60" (1500mm), 72" (1800 mm)	7660		
	10	Discharge Housing, AL 6061	6651	1	
	11*	Seal, PTFE	2195	1	
	12	Knurled Nut, AL 6061	6656	1	
	13	Hose Barb, AL 6061		1	
	.75" (19 mm)	6658			
	1" (25 mm)	6657			
14	Inner Tube, AL 6061		1		
	27" (700 mm)	6670			
	39" (1000 mm)	6671			
	47" (1200 mm)	6672			
	60" (1500 mm)	6673			
	72" (1800 mm)	6674			
15	Outer Tube, AL 6061		1		
	27" (700 mm)	6680			
	39" (1000 mm)	6681			
	47" (1200 mm)	6682			
	60" (1500 mm)	6683			
	72" (1800 mm)	6684			
16	O-Ring, Viton	7655	2		
17	Pump Housing, AL 6061	6685	1		
18*	Bushing, Carbon Graphite	7606	1		
19*	Rotor/Impeller		1		
	High Volume Rotor, PTFE	7706			
	High Pressure Impeller, PTFE	4608HH			
20	Pump Foot, AL 6061		1		
	High Volume	6686			
	High Pressure	6786			
	Repair Kit (Includes Items 3, 4, 5, 11, 18 & 19)	7054	1		

# SPE Barrel Mixers

## New high efficiency mixers for mixing directly in all types of barrels

- Made from high quality stainless steel, 1.4571
- Direct installation in standard barrels.
- Special high efficiency hinged propeller
- Additional support – no vibrations

### Technical Specifications

<b>Part Number</b>	<b>SPE-M0060</b>
<b>Motor</b>	0,37W
<b>Power Supply</b>	3x230/400V, 50Hz
<b>Speed</b>	900 r/min
<b>Shaft Length</b>	520 mm
<b>Material in contact with liquid</b>	SS, 1.4571
<b>Drum Connection</b>	2" male threads
<b>Weight</b>	13,5 kg
<b>Mixing Element</b>	Special two bladed, hinged propeller. Ø=100mm
<b>Design Viscosity</b>	500Cp

<b>Part Number</b>	<b>SPE-M0200</b>
<b>Motor</b>	0,75 kW
<b>Power Supply</b>	3x230/400V, 50Hz
<b>Speed</b>	1450 r/min
<b>Shaft Length</b>	850 mm
<b>Material in contact with liquid</b>	SS, 1.4571
<b>Drum Connection</b>	2" male threads
<b>Weight</b>	App. 18 kg
<b>Mixing Element</b>	Special two bladed, hinged propeller. Ø=100mm
<b>Design Viscosity</b>	500Cp

Other mixers and agitators available.

Please see catalog;

**Mixers, Agitators, Lifting- & Heating Systems**

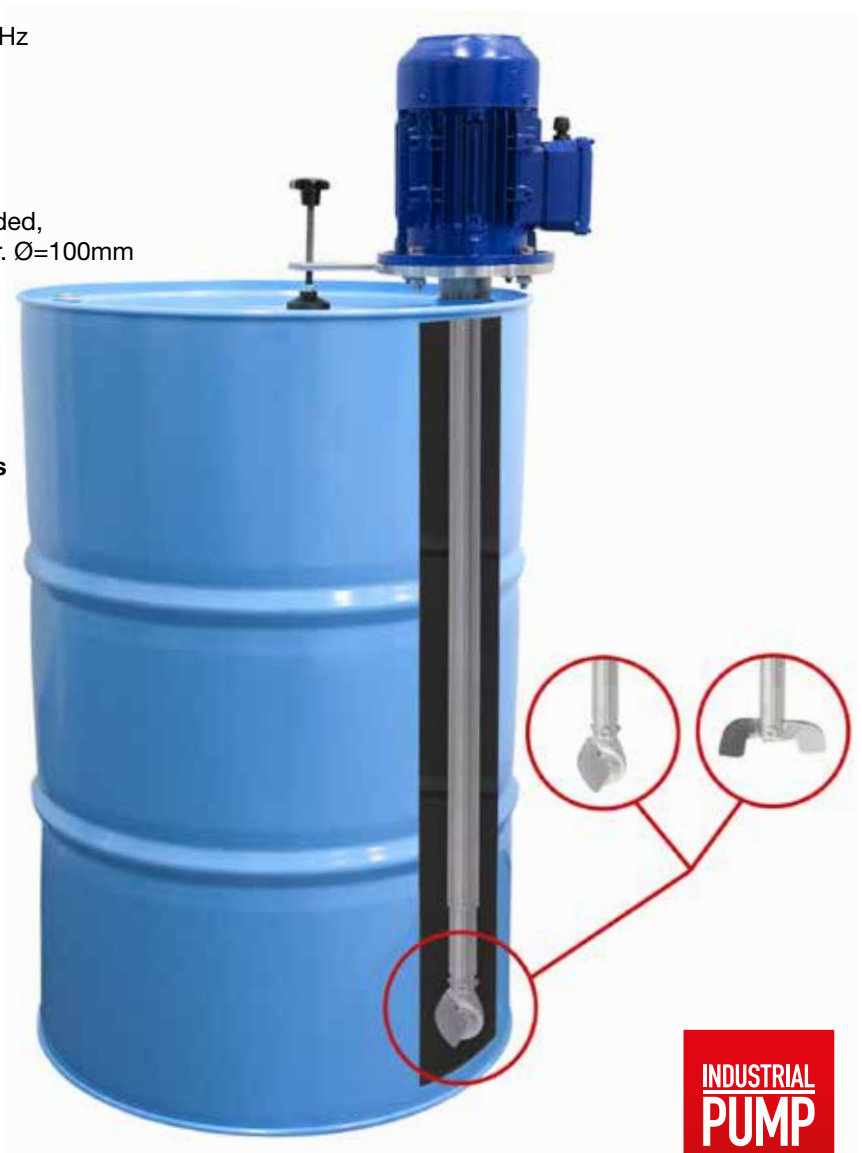

# Hand Pumps

Standard Pump Europe's hand pumps are engineered for transferring mainly oils from drums and storage tanks.

## SPE OK 9B



### Common Applications

- Motor oil to SAE 80
- Gearbox oil to SAE 80
- Hydraulic oil to SAE 80

### Technical Specifications

<b>Part Number</b>	SPE OK 9B
<b>Wetted Parts</b>	Steel, Steel galvanised, Brass, Zinc casting alloy, POM, Novotex, NBR, Ramilon, Lupolen (not media touched)
<b>Pump Design</b>	Simple-acting reciprocating piston pump
<b>Flow Rate</b>	approx. 0,25 liter/stroke
<b>Outlet Manifold</b>	Drip tight outlet
<b>Barrel Connection</b>	G 2"
<b>Suction Pipe</b>	840 mm
<b>Clasp for Padlock</b>	
<b>Adjustable Drum Screw Connector</b>	

OBS! Min. of order quantity: 5 pcs

## SPE K10 C



### Common Applications

- Diesel
- Petroleum
- Heating Oil EL/L
- Anti-freeze (undiluted)
- Fuels (AI-III)
- Low viscosity mineral oils

















### Technical Specifications

<b>Part Number</b>	SPE K10 C
<b>Wetted Parts</b>	Steel, Steel galvanised, Brass, Zinc casting alloy, POM, Novotex, NBR, Ramilon, Lupolen (not media touched)
<b>Pump Design</b>	Simple-acting reciprocating piston pump
<b>Flow Rate</b>	approx. 0,25 liter/stroke
<b>Outlet Manifold</b>	Outlet clip for hose connection DN19 hose
<b>Barrel Connection</b>	M64 x 4 and G 2"
<b>Telescopic Suction Pipe</b>	470 mm to 925 mm
<b>Outlet Hose</b>	1,5 m with outlet bend of galvanised steel
<b>Directive and Classification</b>	AtEx – II 2/2G c IIA T3











OBS! Min. of order quantity: 5 pcs

# Accessories For Centrifugal Pumps

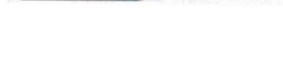
## Hand Nozzels

	Part Number	Description	Dimensions		Seal material
	9016	Polypropylene	3/4" O.D. (19 mm)	Hose Barb Intake	Viton®
	9016E	Polypropylene	3/4" O.D. (19 mm)	Hose Barb Intake	EPDM
	9071	Polypropylene	3/4" O.D. (19 mm)	Hose Barb Intake	Viton®
	9071E	Polypropylene	3/4" O.D. (19 mm)	Hose Barb Intake	EPDM
	9070	Polypropylene	1" O.D. (25 mm)	Hose Barb Intake	Viton®
	9070E	Polypropylene	1" O.D. (25 mm)	Hose Barb Intake	EPDM
	9095	Stainless 316	1" O.D. (25 mm)	Hose Barb Intake	Viton®
	9096	Stainless 316	3/4" O.D. (19mm)	Hose Barb Intake	Viton®
	SPE-9097	Stainless 316	1" O.D. (25 mm)	Hose Barb Intake	PTFE
	SPE-9098	Stainless 316	3/4" O.D. (19mm)	Hose Barb Intake	PTFE
	9090	PVDF	1" O.D. (25 mm)	Hose Barb Intake	Viton®
	9090E	PVDF	1" O.D. (25 mm)	Hose Barb Intake	EPDM
	9091	PVDF	3/4" O.D. (19 mm)	Hose Barb Intake	Viton®
	9091E	PVDF	3/4" O.D. (19 mm)	Hose Barb Intake	EPDM
	SPE-9030A	Aluminium	1" O.D. (25 mm)	Hose Barb Intake	Buna
	SPE-9030B	Aluminium	3/4" O.D. (19 mm)	Hose Barb Intake	Buna

## Discharge Hoses

	Part Number	Description
	LH-9032	Clear Braided PVC 1" I.D. x 1.25" O.D. (25 mm x 32 mm) Max. Temperature: 40 °C Max. Operating Pressure: 10 bar / 20 °C
	LH-9033	Clear Braided PVC 3/4" I.D. x 1" O.D. (19 mm x 25 mm) Max. Temperature: 40 °C Max. Operating Pressure: 13 bar / 20 °C
	LH-2536	NBR/Nitril, black 1" Hose for diesel and petrol Max. Temperature: 60 °C Max. Operating Pressure: 20 bar / 20 °C
	9034M-B	<div style="display: flex; justify-content: space-around; align-items: center;"> <div style="text-align: center;">  </div> <div style="text-align: center;">  </div> <div style="text-align: center;">  </div> <div style="text-align: center;">  </div> <div style="text-align: center;">  </div> <div style="text-align: center;">  </div> </div> Chemical, AtEx and Food Hose 3/4" I.D. x 1.22" O.D. (19 x 31 mm) (Part no. 9034M-B1) 1" I.D. x 1.50" O.D. (25 x 38 mm) (Part no. 9034M-B2) Max. Operating Pressure: 16 bar Datasheet on request.

Viton® is a registered trademark of DuPont Dow Elastomers.

# Accessories For Centrifugal Pumps

## Barrel Adapters



Part Number	Material	Description
1743	Polypropylene (for SP-Mini)	2" O.D. (51 mm)
SPE-9015	Polypropylene	2" O.D. (51 mm)
8802	Stainless 304 (for 6600 / 6700 & 7600 / 7700 Series)	2" O.D. (51 mm)
9022	Stainless 304 (for AL Series)	2" O.D. (51 mm)

## Fume Barriers



Part Number	Material	Description
9018	Polypropylene	2" (51 mm), EPDM Seal
8804	Stainless 304 (for 6600 / 6700 & 7600 / 7700 Series)	2" (51 mm), EPDM Seal
9019	Stainless 304 (for SS Series)	2" (51 mm), EPDM seal
9024	Stainless 304 (for AL Series)	2" (51 mm), EPDM seal

## IBC Accessories



Part Number	Material	Description
SPE-9020	Pump adaptor for IBC cap	Trisure x Ø 42 mm
SPE-9020A	Special cap	Ø150 mm
SPE-9020B	Special cap	Ø225 mm
SPE-9021A	Thread adaptor for IBC cap	Trisure x R2"

## Suction Stainers



Part Number	Material	Mesh Size
9011	Polypropylene	.63" x .098" (16 x 2,5 mm)
7012	Stainless 316 (for 6600 / 6700 & 7600 / 7700 Series)	.58" x .051" (14,7 x 1,3 mm)
9012	Stainless 316 (for SS & AL Series)	.58" x .051" (14,7 x 1,3 mm)
9043	PVDF (Kynar®)	.63" x .098" (16 x 2,5 mm)

## Quick Disconnect



Part Number	Material	Description
125A100C	Polypropylene	1.25" Thread x 1" Barb (32 mm x 25 mm)

## Wall Bracket & Hand Clamp



Part Number	Description
9006A	Stainless Steel Wall Storage Bracket Designed for Pump Storage
9005	Stainless Steel 316, Engineered to Vertically Stabilize Pump

# Heating Jackets (AtEx incl.) for 200 ltr. drums and 1000 ltr. IBC

Standard Pump Europe heating jackets are the right solution for keeping media at the required temperature. They are made of water resistant materials and are IP 40 classified (IP54 on request). The heating jackets come with quick release buckles for easy installation and removal. All our heating jackets are supplied with 3 meters of braided power cable and fitted with a 0 to +90°C capillary thermostat. The heating jackets are suitable for metal, PP, PE drums and containers.



## Heating Jackets for 200 ltr. drums

**Part Number** SPE-0200-00  
**Power** 230V AC – 1 x 1200 W  
**Dimensions** 1990 x 800 mm  
**Temperature** 0 – 90 °C

**Part Number** SPE-0200-01  
**Power** 230V AC – 1 x 530 W  
**Dimensions** 1990 x 450 mm  
**Temperature** 0 – 90 °C

**Part Number** SPE-0200-LID (to be ordered separately)  
Insulation lid for 200 ltr. drums

## High Temperature Heating Jacket for 200 ltr. drums

**Part Number** SPE-0200-02  
**Power** 230V AC – 1 x 1200 W  
**Dimensions** 1990 x 800 mm  
**Temperature** 0 – 200 °C

**Part Number** SPE-0200-LID (to be ordered separately)  
Insulation lid for 200 ltr. drums



## Heating Jackets for 1000 ltr. IBCs

**Part Number** SPE-1050-02  
**Heating Zones** 2  
**Power** 230V AC – 2 x 1000 W  
**Dimensions** 4400 x 1000 mm  
**Temperature** 0 – 90 °C

**Part Number** SPE-1050-03  
**Heating Zones** 3  
**Power** 230V AC – 3 x 1000 W  
**Dimensions** 4400 x 1000 mm  
**Temperature** 0 – 90 °C

**Part Number** SPE-1050-LID (to be ordered separately)  
Insulation lid for IBC



## Base heater for 200 ltr. drums

**Part Number** SPE-0200-BASE  
**Diameter** 550 mm  
**Thermostat** 0 – 120 °C  
**Power** 230V – 900W

# AtEx Heating Jackets for 200 ltr. drums and 1000 ltr. IBC

Standard Pump Europe AtEx certified heating jackets are the right solution for heating and maintaining media at the required temperature. They are made of water resistant materials and are IP 65 classified. The AtEx certified heating jackets come with quick release buckles for easy installation and removal. The heating jackets are suitable for metal and PE drums and containers. Complete PTFE-(Teflon®) coating for maximum long-life cycle and highest reliability against acids, solvents etc.



## AtEx Heating Jackets for 200 ltr. drums

<b>Part Number</b>	SPE-0200-EX
<b>Power</b>	230V AC – 1 x 1050 W
<b>Heating Element</b>	Self-limiting
<b>Temperature Range</b>	To be specified
<b>Dimensions</b>	1990 x 800 mm

<b>Part Number</b>	SPE-0200-LIDEX (to be ordered seperately) Insulation lid for 200 ltr. drums
--------------------	--



## AtEx Heating Jackets for 1000 ltr. IBCs

<b>Part Number</b>	SPE-1000-EX
<b>Heating Zones</b>	2
<b>Power</b>	230V AC – 1 x 1500 W
<b>Heating Element</b>	Self-limiting
<b>Temperature Range</b>	To be specified
<b>Dimensions</b>	4400 x 1000 mm

<b>Part Number</b>	SPE-1000-LIDEX (to be ordered seperately) Insulation lid for IBC
--------------------	---

## Technical Specifications

<b>Heating Element</b>	Self-limiting
<b>Ambient Temperature</b>	- 55 °C to + 55 °C (jackets for higher temperature on request)

### Directive and Classification

AtEx 2014 / 34 / EC – II 3G Ex e II T2 – T5



# Progressive Cavity Pumps and Lifting Device Systems



Lifting Device Systems details - please see page 46.



# Performance Curves for SP-700DD and SP-700SR series

## 751 Series Pumps

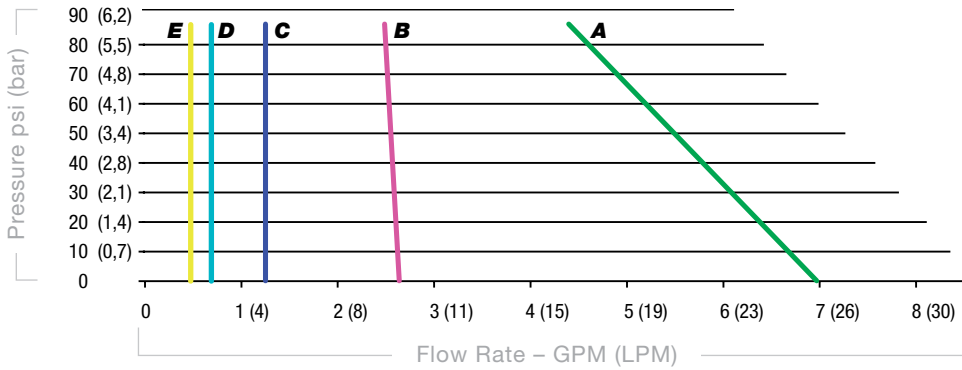

### SP-700DD series

	Viscosity cps (mPas)	Electric KW	Air KW
A	1	0,55	1,5
B	10,000	0,55	1,5
C	30,000	0,75	3
D	60,000	0,75	3
E	100,000	1,1	3,7

### SP-700SR series

	Viscosity cps (mPas)	Electric Motor
A	1	SPE-950, SP-ENC, SP-440EX
B	10,000	SPE-950, SP-ENC, SP-440EX
C	30,000	SPE-950, SP-ENC, SP-440EX

## 752 Series Pumps

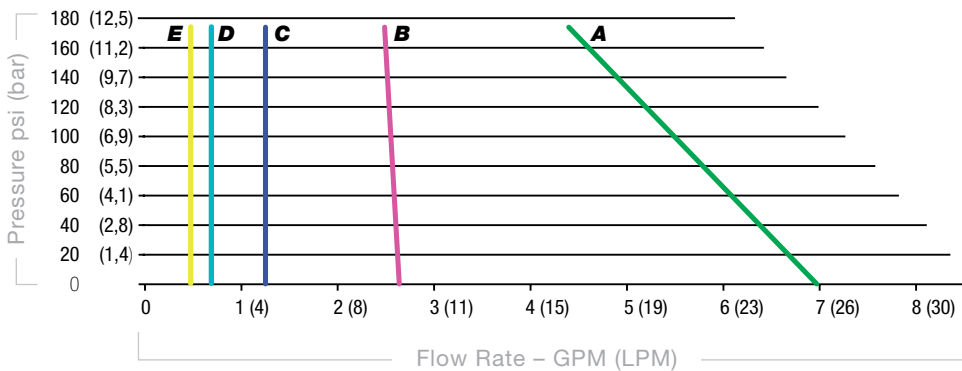

### SP-700DD series

	Viscosity cps (mPas)	Electric KW	Air KW
A	1	0,55	1,5
B	10,000	0,55	1,5
C	30,000	0,75	3
D	60,000	0,75	3
E	100,000	1,1	3,7

### SP-700SR series

	Viscosity cps (mPas)	Electric Motor
A	1	SPE-950, SP-ENC, SP-440EX
B	10,000	SPE-950, SP-ENC, SP-440EX
C	30,000	SPE-950, SP-ENC, SP-440EX

## 1851 Series Pumps

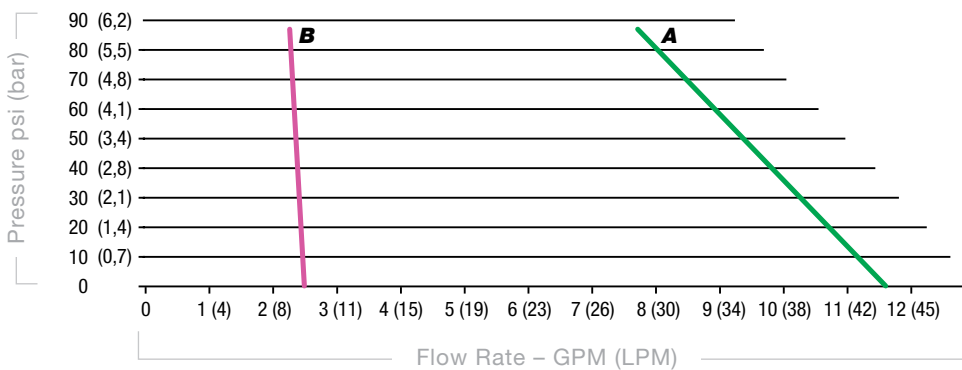

### SP-700DD series

	Viscosity cps (mPas)	Electric KW	Air KW
A	1	0,55	1,5
B	10,000	0,55	1,5

### SP-700SR series

	Viscosity cps (mPas)	Electric Motor
A	1	SPE-950, SP-ENC, SP-440EX
B	10,000	SPE-950, SP-ENC, SP-440EX

### Technical Notes

- Performance Curves are intended to be used as a guide only as individual results may vary.
- Pump Stator Elastomers (Teflon or Buna) may vary performance.
- Performance Curves were created using a 900 RPM motor. Reducing motor speed will decrease pump performance. Do NOT increase motor speed above 900 RPM's.
- Pump Curves were created with a Newtonian Polymer (Viscosity remains constant regardless of shear). Non-Newtonian materials (viscosity does not remain constant with shearing) may vary performance.



# SP-700SR Progressive Cavity Series

STANDARD's 700SR Series pumps are engineered to transfer viscous materials from drums and ToteTanks®. The progressive cavity design delivers a continuous flow of material with little product degradation. Pumps are available with TEFC and Hazardous Duty motors. Maximum viscosity is 25,000 cps (mPas).

## Motor Drives



SP-ENC Series



SPE-950 Series

Note: Refer to page 6-7 motor information



## Common Applications

- Polymers
- Adhesives
- Paints
- Resins
- Oils & Greases
- Varnishes

## Technical Specifications

<b>Design</b>	Progressive Cavity / Positive Displacement	
<b>Max. Viscosity</b>	• 751 & 752 Series	25,000 cps (mPas)
	• 1851 Series	10,000 cps (mPas)
<b>Discharge Port</b>	1½" (38 mm) Hose Barb, Optional 1.25" (32 mm)	
<b>Stator Materials</b>	PTFE	
<b>Mechanical Seal</b>	SiC/Viton®/SiC	
<b>Immersion Lengths</b>	27" (700 mm), 39" (1000 mm), 47" (1200 mm) <i>Please add 5" (127 mm) to the immersion length of pump for the 752 Series pumps.</i>	
<b>Wetted Material</b>	Tube & Rotor Assembly: Stainless Steel 316	
<b>Motor Drives</b>	SP-ENC Series, SPE-950 Series	
<b>Fittings</b>	Threaded design enables operator to disassemble pump quickly for cleaning, maintenance and inspection	
<b>Max. Flow Rate</b>	• 1851 Series	45 LPM based on water
	• 751 & 752 Series	26 LPM based on water
<b>Max. Discharge Pressure</b>	• 751 & 1851 Series	6 bar
	• 752 Series	12 bar
<b>Max. Temperature</b>	• Teflon Stator	148 °C
<b>Max. Solid Size</b>	.25" (6 mm)	

## Benefits

- Easy To Clean & Maintain
- Interchangeable Motor Drives
- Continuous Flow
- Low Shearing Properties
- Threaded Components

Model	Immersion Length	Stator Material	Gross Wt.
SP-700SR-751P-39	39" (1000 mm)	PTFE	9,0 kg
SP-700SR-752P-39	44" (1120 mm)	PTFE	10,0 kg
SP-700SR-1851P-39	39" (1000 mm)	PTFE	10,5 kg
SP-700SR-751P-47	47" (1200 mm)	PTFE	10,5 kg
SP-700SR-752P-47	52" (1320 mm)	PTFE	11,0 kg
SP-700SR-1851P-47	47" (1200 mm)	PTFE	10,5 kg

Note: For this pump, the following items are included with the pump: 730 (gasket), 727 (wing nut), 729 (hose barb).

Note: This pump is intended for intermittent duty use only. Viton® is a registered trademark of DuPont Dow Elastomers.

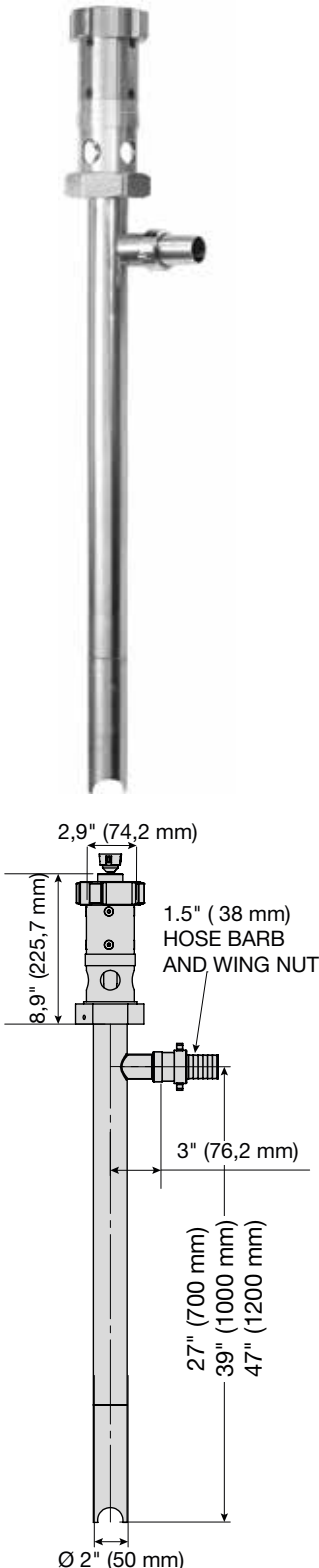

# SP-700SR Progressive Cavity Series Spare Parts

## SP-700SR Spare Parts

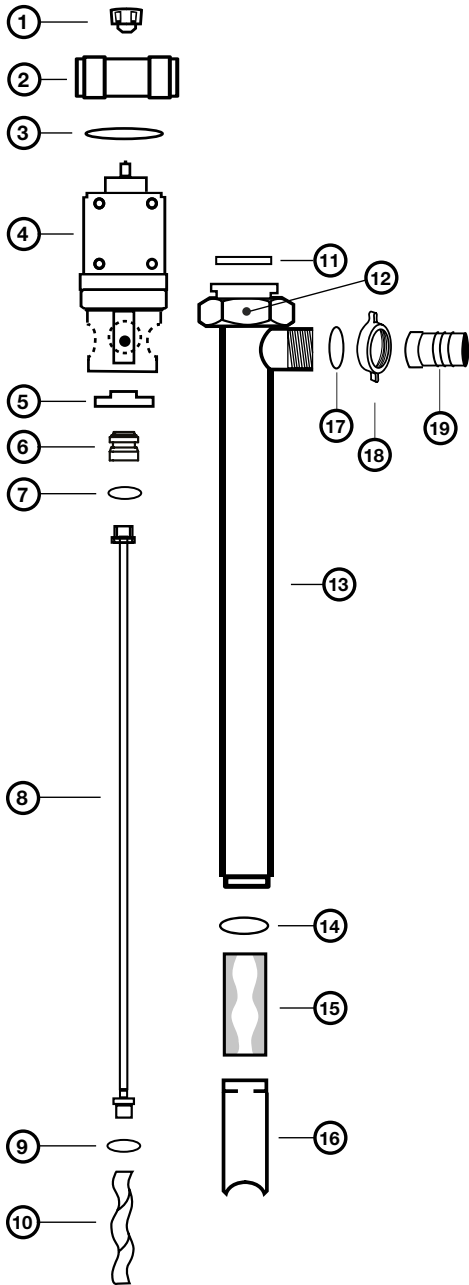

Ref #	Description	Part Number	Qty
1	Pump Coupling	1004	1
2	Connection Nut	8842	1
3	Snap Ring, SS316	8208	1
4	Gear Reduction Unit	779	1
5	Mechanical Seal Bushing	702	1
6	Mechanical Seal, SIC	703	1
7	Gasket, PTFE	735	1
8	Drive Shaft, SS316		1
	Pump Sizes - SP-1851-39	705	
	Pump Sizes - SP-751-39, SP-752-39, SP-1851-47	706	
	Pump Sizes - SP-751-47, SP-752-47	707	
9	Gasket, PTFE	731	1
10	Rotor, SS316		1
	Size 751	708	
	Size 752	709	
	Size 1851	710	
11	Gasket, PTFE	738	1
12	Set Screw, SS316	757	1
13	Outer Tube Assembly, SS316		1
	SP-1851-39	771	
	SP-751-39, SP-752-39, SP-1851-47	772	
	SP-751-47, SP-752-47	773	
14	Ring, SS316 (For Use with PTFE Stator Only)	0016	1
15	Stator Insert, PTFE		1
	Size 751	822	
	Size 752	823	
	Size 1851	824	
16	Stator Tube, SS316		1
	Size 751	874	
	Size 752	875	
	Size 1851	876	
17	Gasket, PTFE	730	1
18	Wing Nut, SS316	727	1
19	Hose Barb, SS316		1
	1.25" (32 mm)	728	
	1.5" (38 mm)	729	

\* does not include Stator Tube #13 (PFTE Stator only).

# SP-700DD Progressive Cavity Series

STANDARD's 700DD Series pumps are engineered to transfer viscous materials from drums, Intermediate Bulk Containers (IBC) and large storage vessels. Utilizing the principle of positive displacement, these pumps deliver a continuous flow of material with little product degradation. Pumps are available with a TEFC electric or air powered motors. Maximum viscosity is 100,000 cps (mPas).

## Common Applications

- Polymers
- Resins
- Adhesives
- Oils & Greases
- Paints
- Varnishes

## Technical Specifications

<b>Design</b>	Progressive Cavity / Positive Displacement	
<b>Max. Viscosity</b>	• 751 & 752 Series	100,000 cps (mPas)
	• 1851 Series	10,000 cps (mPas)
<b>Discharge Port</b>	1½" (38 mm) Hose Barb, Optional 1.25" (32 mm)	
<b>Stator Materials</b>	PTFE	
<b>Mechanical Seal</b>	SiC/Viton®/SiC	
<b>Immersion Lengths</b>	27" (700 mm), 39" (1000 mm), 47" (1200 mm) <i>Please add 5" (127 mm) to the immersion length of pump for the 752 Series pumps</i>	
<b>Wetted Material</b>	Tube & Rotor Assembly: Stainless Steel 316	
<b>Motor Drives</b>	IEC & Pneumatic	
<b>Fittings</b>	Threaded design enables operator to disassemble pump quickly for cleaning, maintenance and inspection	
<b>Mounting Flange</b>	B14/C140-160	
<b>Max. Flow Rate</b>	• 1851 Series	45 LPM based on water
	• 751 & 752 Series	26 LPM based on water
<b>Max. Discharge Pressure</b>	• 751 & 1851 Series	6 bar
	• 752 Series	12 bar
<b>Max. Temperature</b>	• Teflon Stator	148 °C
<b>Max. Solid Size</b>	.25" (6 mm)	

## Motor Drives



IEC



Pneumatic

Note: Refer to page 38 for motor information

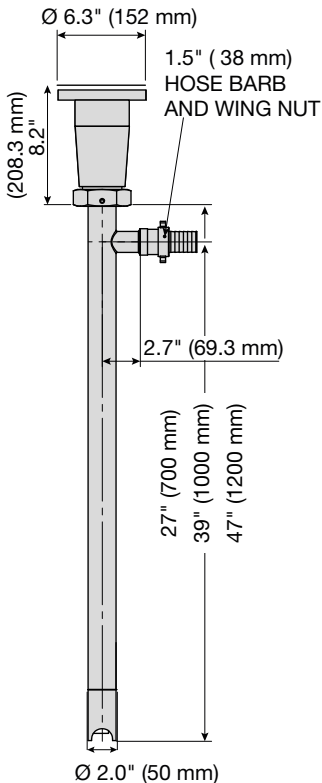

## Benefits

- Easy To Clean & Maintain
- Continuous Flow
- Threaded Components
- Interchangeable Motor Drives
- Low Shearing Properties

Model	Immersion Length	Stator Material	Gross Wt.
SP-700DD-751P-39	39" (1000 mm)	PTFE	10,8 kg
SP-700DD-752P-39	44" (1120 mm)	PTFE	11,3 kg
SP-700DD-1851P-39	39" (1000 mm)	PTFE	10,4 kg
SP-700DD-751P-47	47" (1200 mm)	PTFE	11,3 kg
SP-700DD-752P-47	52" (1320 mm)	PTFE	11,8 kg
SP-700DD-1851P-47	47" (1200 mm)	PTFE	11,3 kg

Note: For this pump, the following items are included with the pump: 730 (gasket), 727 (wing nut), 729 (hose barb), flange, coupling insert and flange bolt

Viton® is a registered trademark of DuPont Dow Elastomers.



# SP-700DD Progressive Cavity Series Spare Parts

SP-700DD Spare Parts		Ref #	Description	Part Number	Qty
	1	Motor Coupling (Not Included w/ Pump Tube)			1
		SP-502 & SP-A8 Models – 24 mm	740		
		SP-A4 Model - 14 mm	744		
		SP-A6 Model - 19 mm	747		
		SP-512 & SP-522 Models – 28 mm	746		
	2	Coupling Insert	745		1
	3	Flange Bolt	758		6
	4	Motor Mount Flange, Aluminum			1
	5	Bearing Housing Assembly, Aluminum	759		1
	6	Mechanical Seal Bushing	702		1
	7	Mechanical Seal, SIC	703		1
	8	Gasket, PTFE	735		1
	9	Drive Shaft, SS316			1
		SP-1851-39	705		
		SP-751-39, SP-752-39, SP-1851-47	706		
		SP-751-47, SP-752-47	707		
	10	Gasket, PTFE	731		1
	11	Rotor, SS316			1
		Size 751	708		
		Size 752	709		
	Size 1851	710			
12	Gasket, PTFE	738		1	
13	Set Screw, SS316	757		1	
14	Outer Tube Assembly, SS316			1	
	SP-1851-39	771			
	SP-751-39, SP-752-39, SP-1851-47	772			
	SP-751-47, SP-752-47	773			
15	Ring, SS316 (For Use with PTFE Stator Only)	0016		1	
16	Stator Insert, PTFE			1	
	Size 751	822			
	Size 752	823			
	Size 1851	824			
17	Stator Tube, SS316			1	
	Size 751	874			
	Size 752	875			
	Size 1851	876			
18	Gasket, PTFE	730		1	
19	Wing Nut, SS316	727		1	
20	Hose Barb, SS316			1	
	1.25" (32 mm)	728			
	1.5" (38 mm)	729			

# Motors for SP-700DD Pumps



## Electric Motor 190/380 // 230/460 / 3 / 50-60 Hz

Part Number	HP	kW	RPM	Enclosure	Frame	Flange	Gross WT
SP-502	0.75	0,55	750-900	TEFC (IP55)	90LC	B14/C140	25,5 kg
SP-522	1.5	1,1	750-900	TEFC (IP55)	100LC	B14/C160	35,5 kg
0017	Motor wiring for 230V/3/50-60 Hz						

## Pneumatic Motor



Part number	HP	kW	RPM	Air Consumption	Frame	Air Conn. Inch (mm)	Gross WT
SP-A4	2.0	1,5	300-900	80 CFM @ 100 psi 37 L/Sec @ 7 bar	IEC#72/D71	3/8"	5,4 kg
SP-A6	4.0	3,0	300-900	130 CFM @ 100 psi 65 L/Sec @ 7 bar	IEC#72/D80	1/2"	11,0 kg
SP-A8	5.0	3,7	300-900	170 CFM @ 100 psi 80 L/Sec @ 7 bar	IEC#72/D90	1/2"	11,8 kg

Note: Optimal pneumatic motor speed is 900 RPM. Failure to comply may result in pump damage or premature failure.

# Pneumatic Motor – SP-A4 Spare Parts

Ref #	Description	Part Number	Qty
	Service kit – only service kits are available for parts replacement	K206C	1
	* Denotes parts included in the Service Kit		
1	Shaft Seal	B2328*	1
2	Bearing, Drive End	AB519*	1
2A	Bearing, Dead End	AA299J*	1
3	End Plate, Drive	AK425A	1
4	Rotor Assembly	AM455C	1
5*	Vane		4
6*	Push Pin		4
7*	Vane, Spring		2
8	Body	AM410M	1
9	Shims	B330*	2
10	End Plate, Dead	AB622M	1
11	End Cap, Gasket	AA46*	1
12	End Cap, Dead	AM307D	1
13	Muffler Assembly	AC980	1
14	Muffler Felt	AC983*	1

Body styles may differ, depending on specific models.

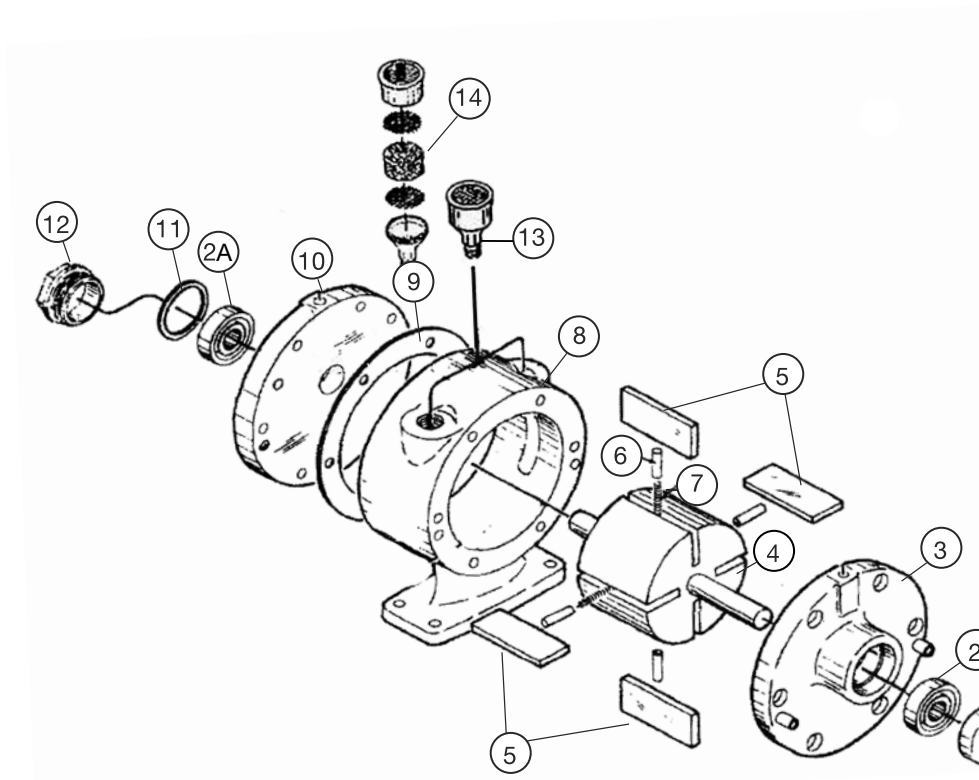

# Pneumatic Motor – SP-A6 Spare Parts

Ref #	Description	Part Number	Qty
	Service kit – only service kits are available for parts replacement * Denotes parts included in the Service Kit	K281A	1
1	End Cap, Drive End	AC998	1
2	Shaft Seal	AK423*	1
3	O-Ring	AC989*	1
4	Bearing, Drive End	AC894B*	1
5	Dowel Pin	AB162C	4
6	End Plate, Drive	AK424	1
7	Body Gasket	AD641*	2
8	Body	AD665D	1
9	Key	AK422	1
10	Rotor Assembly	AD648E	1
11	Push Pin	AD655A*	2
12	Vane, Spring	AD692*	4
13	Vane	AD691*	4
14	End Plate, Dead	AD651	1
15	Bearing, Dead End	AB519*	1
16	End Cap, Gasket	AD644*	1
17	End Cap, Dead End	AD643	1
	Muffler Assembly	AC990	1
	Felt	AC993*	1

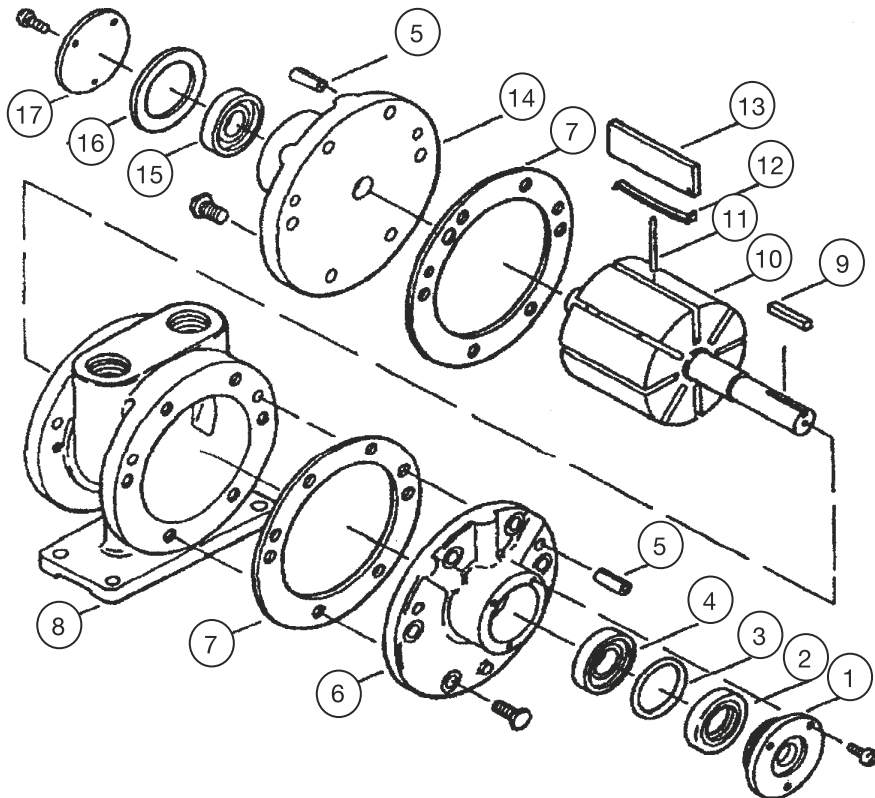



# Pneumatic Motor – SP-A8 Spare Parts

Ref #	Description	Part Number	Qty
	Service kit – only service kits are available for parts replacement * Denotes parts included in the Service Kit	K282A	1
1	End Cap, Drive End	AC998	1
2	Shaft Seal	AK423*	1
3	O-Ring	AC989*	1
4	Bearing, Drive End	AC894B*	1
5	Dowel Pin	AB162C	4
6	End Plate, Drive	AK424	1
7	Body Gasket	AD641*	2
8	Body	AD665D	1
9	Key	AK422	1
10	Rotor Assembly	AD648E	1
11	Push Pin	AD655A*	2
12	Vane, Spring	AD692*	4
13	Vane	AD691*	4
14	End Plate, Dead	AD651	1
15	Bearing, Dead End	AB519*	1
16	End Cap, Gasket	AD644*	1
17	End Cap, Dead End	AD643	1
	Muffler Assembly	AC990	1
	Felt	AC993*	1

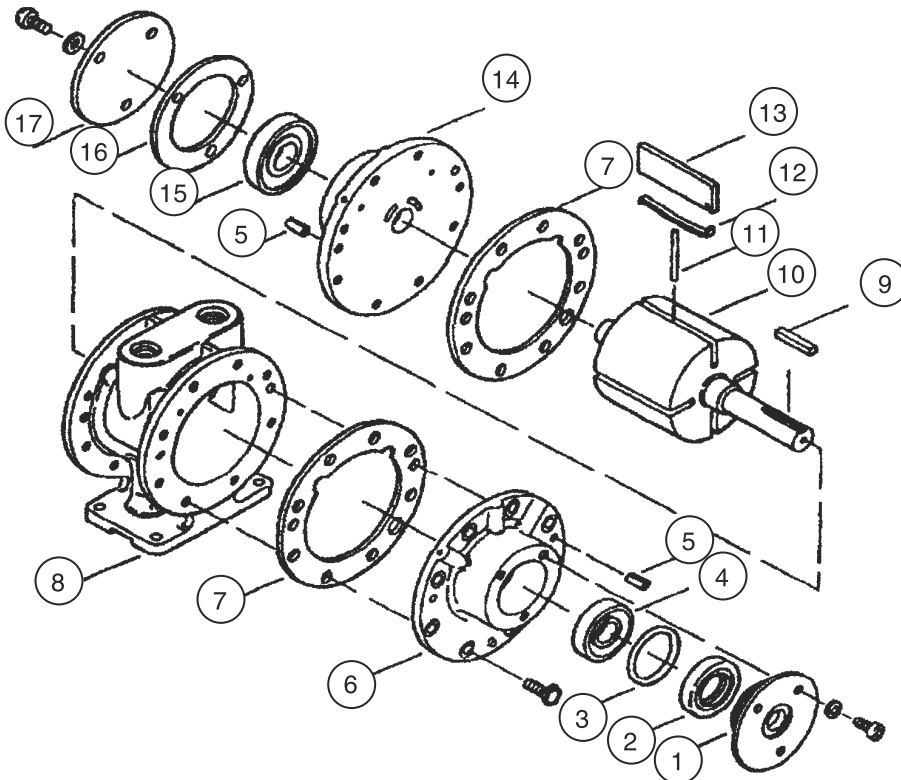

# Lifting Device Systems for Drum Pumps and Motors

## Device for lifting drum pumps or mixers with motors in and out of IBC containers or drums



<b>Description</b>	Stand with pneumatic lifting mechanism
<b>Max. Lifting Weight</b>	90 kg
<b>Power Supply</b>	Depending on the mounted equipment (drum pump or mixer). automatic on/off at upper and lower end of lifting range other power supply, please contact your distributor

### Outer Dimensions (mm):

<b>Outside</b>	1010 mm x 1600 mm
<b>Inside</b>	850 mm (to fit to an IBC container)
<b>Heights</b>	App. 2000 mm
<b>Total Lift</b>	App. 1250 mm
<b>Total Height</b>	App. 2900 mm

### **Material/Construction:**

<b>Anodized Extruded Aluminium Profile</b>	80 mm x 80 mm
<b>Wheels</b>	2 x swivel castors, 2 x fixed castors
<b>Assembled</b>	Semi

## Basic Lifting Device



<b>General Description</b>	Stand with manual winch
<b>Max. Lifting Weight</b>	60 kg
<b>Outer Dimensions:</b>	
Height	2700 mm
Length	1400 mm
Width	1200 mm
<b>Shipping Weight</b>	52 kg
<b>Materials</b>	Power coated steel
<b>Wheels</b>	2 x swivel castors 2 x fixed castors
<b>Assembled</b>	Semi

# Accessories for Progressive Cavity Pumps



## Discharge Hose Clamp

Part Number	Description
9038	Malleable Iron Two Bolt Clamp Gripping Ridges, Reinforced Lugs Hose Size from 1-48/64" to 2-3/64" (44,50 mm to 52 mm) Torque Value: 27 ft. lbs. (3,75 kg/m) for Proper Attachment

## Discharge Hoses



Part Number	Description
9039	Recommended For: High pressure hydraulic oil lines. Tube: Black, oil resistant synthetic rubber. (Nitrile). Reinforcement: One braid of high tensile steel wire. Cover: Black, oil and abrasion resistant synthetic rubber. Flame Resistance: Meets Flame Resistant Designation "GL" Germanischer Lloyd. Meets Flame Resistant Designation "U.S. MSHA" of the US Department of Labor, Mine Safety and Health Administration.

Nom. ID DIN/in/Dash	Nom. OD mm	Bend Radius mm	Vacuum in/mm	Weight kg/m	Temp. Range °C
40 /1.5 /-24	50,5	500	27/685,8	1,59	-34 to 104

<b>Max. Dynamic WP</b> 725/50 psi/bar	<b>Max. Static WP</b> 970/67 psi/bar	<b>Min. Burst Pressure</b> 2900/200 psi/bar
--	---	--



9034M-B3



Chemical, AtEx and Food Hose  
1½" I.D. x 2.01" O.D. (38 x 51mm) Max.  
Operating Pressure: 16 bar  
Datasheet on request.



LH-9034

Clear Braided PVC  
1½" I.D. x 2" O.D. (38 mm x 48 mm)  
Max. Temperature: 40 °C  
Max. Operating Pressure: 5 bar / 20 °C

Pump Hanger



## Pump Hanger

Part Number	Description
743	Pump Hanger Provides a Convenient Solution for Attaching the Pump to a Hoist System



## Quick Disconnect

Part Number	Description
150DSS/150ESS	1.5" (38 mm), SS316 Cam Lever Couplings, Buna N Gaskets, Max. Pressure: 150 psi (10,2 bar).

# Batch Control System – ELECTRIC (Low Viscosity)

**STANDARD's Batch Control System (BCS)** is engineered to control, measure and dispense preset volumes of liquid from drums, IBC's, plating tanks or any large storage vessel. The BCS can be used in an industry where batching, chemical packaging or dilution is required to be accurate and efficient. Simply dial in the desired volume, press ENTER and the BCS delivers a preset volume of liquid virtually hands-free.

## Common Applications

- Chemical Delivery
- Chemistry For Plating Tanks
- Chemical Packaging
- Water Treatment Chemicals

## Features

- 7 Pre-Set Batches
- Measures: Gallons, Liters, Cubic Meters
- Relay Output Signal
- Remote Start Capabilities
- Re-settable Totalizer
- Turbine Paddle Wheel Design
- User Friendly "In Field" Calibration

## Technical Specifications

<b>Available Wetted Parts</b>	Polypropylene, PVDF, Ceramic & Halar
<b>Motor Drive</b>	SP-280 Series (IP44) or SP-ENC Series (IP54) (110 – 120 / 220 – 240v)
<b>Discharge Fitting</b>	1" (25 mm) Hose Barb
<b>Pumping Principle</b>	Centrifugal / Seal-less
<b>Flow Range</b>	15,2 LPM – 102,2 LPM
<b>Max. Viscosity</b>	300 cps (mPas)
<b>Immersion Length</b>	27" (700 mm), 39" (1000 mm), 47" (1200 mm), 60" (1500 mm) or 72" (1800 mm)
<b>Accuracy</b>	± 0.61% of Full Scale und ± 1% of Reading
<b>Max. Temperature</b>	Polypropylene 55 °C, Stainless & PVDF 80 °C
<b>Min. Batch Size</b>	1 Liter



Controller Display

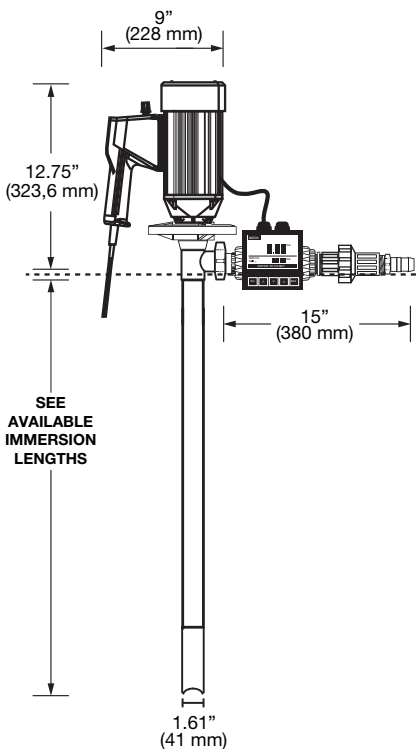

Model Number	Motor Enclosure	Immersion Length	Pump Tube Material
BC2-280-PP-27	Open Drip Proof (IP44)	27" (700 mm)	Polypropylene
BC2-280-PP-39	Open Drip Proof (IP44)	39" (1000 mm)	Polypropylene
BC2-280-PP-47	Open Drip Proof (IP44)	47" (1200 mm)	Polypropylene
BC2-280-PP-60	Open Drip Proof (IP44)	60" (1500 mm)	Polypropylene
BC2-280-PP-72	Open Drip Proof (IP44)	72" (1800 mm)	Polypropylene
BC2-ENC-PP-27	TEFC (IP54)	27" (700 mm)	Polypropylene
BC2-ENC-PP-39	TEFC (IP54)	39" (1000 mm)	Polypropylene
BC2-ENC-PP-47	TEFC (IP54)	47" (1200 mm)	Polypropylene
BC2-ENC-PP-60	TEFC (IP54)	60" (1500 mm)	Polypropylene
BC2-ENC-PP-72	TEFC (IP54)	72" (1800 mm)	Polypropylene
BC2-280-PVDF-27	Open Drip Proof (IP44)	27" (700 mm)	PVDF (Kynar®)
BC2-280-PVDF-39	Open Drip Proof (IP44)	39" (1000 mm)	PVDF (Kynar®)
BC2-280-PVDF-47	Open Drip Proof (IP44)	47" (1200 mm)	PVDF (Kynar®)
BC2-280-PVDF-60	Open Drip Proof (IP44)	60" (1500 mm)	PVDF (Kynar®)
BC2-280-PVDF-72	Open Drip Proof (IP44)	72" (1800 mm)	PVDF (Kynar®)
BC2-ENC-PVDF-27	TEFC (IP54)	27" (700 mm)	PVDF (Kynar®)
BC2-ENC-PVDF-39	TEFC (IP54)	39" (1000 mm)	PVDF (Kynar®)
BC2-ENC-PVDF-47	TEFC (IP54)	47" (1200 mm)	PVDF (Kynar®)



# Batch Control System – ELECTRIC (Low Viscosity) Spare Parts

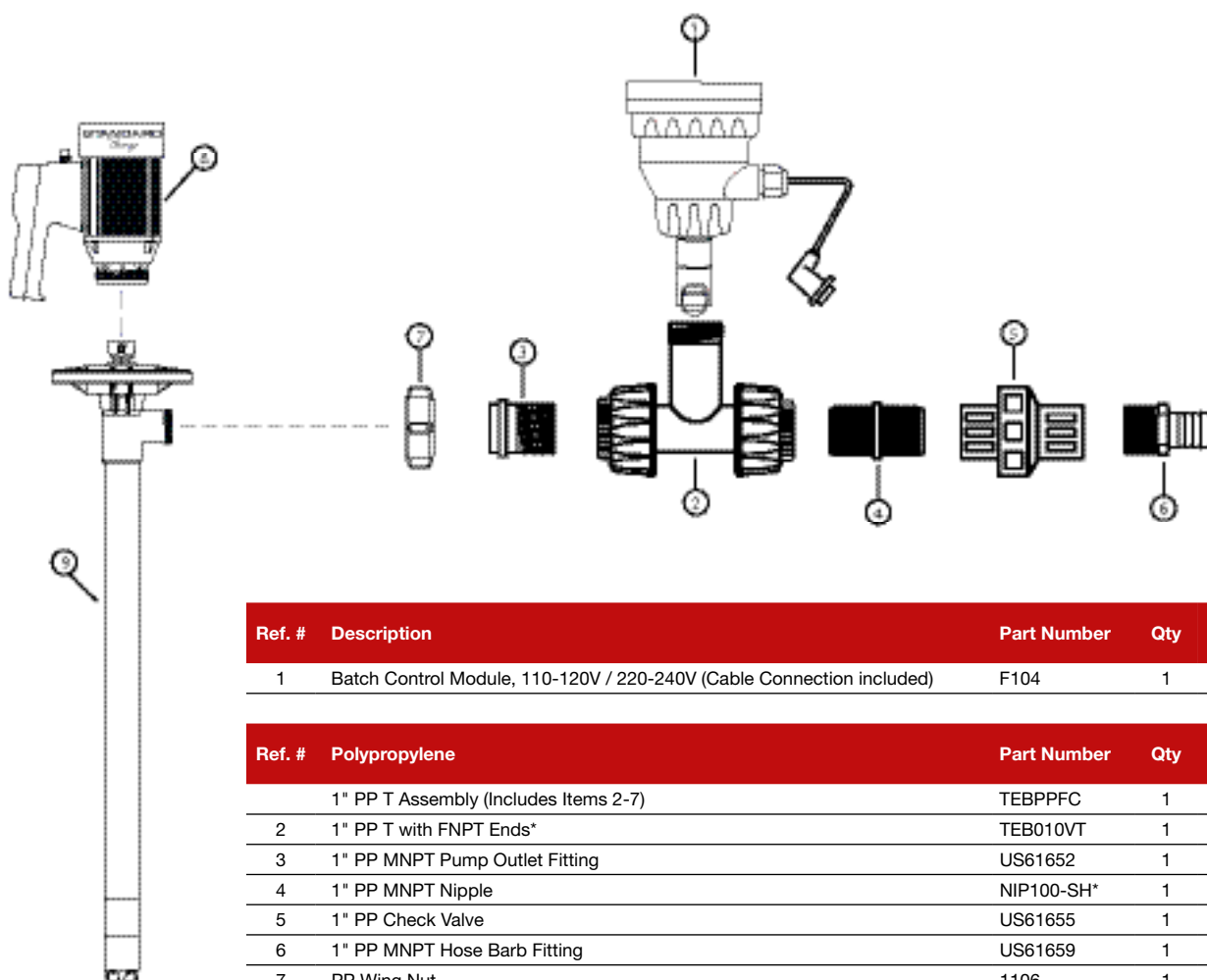

Ref. #	Description	Part Number	Qty
1	Batch Control Module, 110-120V / 220-240V (Cable Connection included)	F104	1

Ref. #	Polypropylene	Part Number	Qty
	1" PP T Assembly (Includes Items 2-7)	TEBPPFC	1
2	1" PP T with FNPT Ends*	TEB010VT	1
3	1" PP MNPT Pump Outlet Fitting	US61652	1
4	1" PP MNPT Nipple	NIP100-SH*	1
5	1" PP Check Valve	US61655	1
6	1" PP MNPT Hose Barb Fitting	US61659	1
7	PP Wing Nut	1106	1

Ref. #	PVDF	Part Number	Qty
	1" PVDF T Assembly (Includes Items 2-7)	TEKPVDFFC	1
2	1" PVDF T with FNPT Ends*	TEK010VT	1
3	1" PVDF MNPT Pump Outlet Fitting	US61661	1
4	1" PVDF MNPT Nipple	4884-020*	1
5	1" PVDF Check Valve	US61664	1
6	1" PVDF MNPT Hose Barb Fitting	US61665	1
7	PVDF Wing Nut	4106	1

Ref. #	Motors	Part Number	Qty
8	Open Drip Proff (IP44) 220-240V/1/50-60Hz with BCS Port Refer to page 9 for Spare Parts	SP-280P-2-BC	1
	TEFC (IP54) 220-240V/1/50-60Hz Refer to page 10 for Spare Parts	SP-ENC-2-BC	1

Ref. #	Pump Tubes
10	Refer to page 12 for Polypropylene Pump Spare Parts and page 19 for PVDF Pump Spare Parts

\* Items marked with an asterisk belong to the same assembly.

**STANDARD's Flow Meters** address a broad scope of applications ranging from inert solutions to aggressive chemicals. These meters utilize a proven paddle wheel design and are available in a variety of sizes and materials. Meters are available in three configurations: Kits for Drum Pumps, Barb Connections, or Permanent Installation.

## Common Applications

- Adding Chemistry to Plating Tanks
- Adding Colors and Fragrances
- Blending Agricultural Products
- Chemical Packaging
- Continuous Flow Measurement
- Gravity Feed Applications From Tanks
- Pump Monitoring

## Features

- Battery Status Indicator
- EE Prom Electronics
- IP65 Enclosure
- Measures Flow Rate and Volume
- Re-settable Totalizer
- Two Line Alphanumeric Display Shows Flow Rate & Total Flow Together
- User Friendly "In Field" Calibration

## Technical Specifications

<b>Volume Flow Range</b>	5 – 90 LPM
<b>Nominal Width</b>	1" external thread
<b>Viscosity Range</b>	0,8 – 40 mPas
<b>Protection Category</b>	IP 65
<b>Operating Pressure</b>	4 bar
<b>Pulsar Output</b>	Optional, 25 Imp/l
<b>Accuracy Uncalibrated*</b>	± 2%
<b>Accuracy Calibrated*</b>	± 1%
<b>Repeat Accuracy</b>	± 0,5 %
<b>Dimensions Approx.</b>	90 x 130 x 61 mm
<b>Weight Approx.</b>	0,3 kg
<b>Operation temperature</b>	-10 °C – +50 °C
<b>Storage temperature</b>	-20 °C – +70 °C
<b>Battery</b>	Li-MO, Type CR ½ AA, 3,6 V 1200 mAh, exchangeable

Part Number	Type	Material*	Intake
SPE-FMT3-PP	Flow Meter Electronic PP, w/o pulse output	PP	Left/Right
SPE-FMT3-PVDF	Flow Meter, Electronic, PVDF, w/o pulse output	PVDF	Left/right
SPE-FMT-CON	Connector kit for FMT3	PVDF	
SPE-FMT-CONP	Connector kit for FMT3	PP	

\*Material of the measuring chamber, measuring chamber lid and the turbine.



FMT3-PVDF



Connector kit for FMT3 (use wing nut from the pump)

The FMOG is a volume meter for flowing fluids working on the principle of an oval gear meter. The product is suitable to be used as a stationary counter, or a hand flow meter. The pulse generator allows use in a fluid management system.

## Common Applications

- Adding Chemistry to Plating Tanks
- Adding Colors and Fragrances
- Blending Agricultural Products
- Chemical Packaging
- Continuous Flow Measurement
- Gravity Feed Applications From Tanks
- Pump Monitoring

## Features

- Battery Status Indicator
- EE Prom Electronics
- IP65 Enclosure
- Measures Flow Rate and Volume
- Re-settable Totalizer
- Two Line Alphanumeric Display Shows Flow Rate & Total Flow Together
- User Friendly “In Field” Calibration



Connector kit for FMOG (use wing nut from pump)

## Technical Specifications

	Low Viscosity (LV)	High Viscosity
<b>Housing</b>	PEEK	Aluminium
<b>Viscosity Range</b>	1 – 20 mPas	20 – 2000 mPas
<b>Protection Category</b>	IP 65	IP 65
<b>Smallest volume flow Q min</b>	2 l/min	1 l/min
<b>Largest volume flow Q max</b>	30 l/min	15 l/min
<b>Max Operating Pressure</b>	4 bar	10 bar
<b>Thread connection</b>	G 1" exit	G ½" inlet
<b>Accuracy after calibration*</b>	± 1% ± 0,5 %	± 1% ± 0,5 %
<b>Dimensions</b>	90 x 135* x 6 mm *flow direction	90 x 135* x 6 mm *flow direction
<b>Weight Approx.</b>	0,5 kg	0,5 kg
<b>Operation temperature</b>	-10 °C – +50 °C	-10 °C – +50 °C
<b>Storage temperature</b>	-20 °C – +70 °C	-20 °C – +70 °C
<b>Battery</b>	Lithium battery	Lithium battery

Part Number	Type	Material*	Intake
SPE-FMOG-ALU-HV	FMOG without pulse output	ALU	left
SPE-FMOG-ALU-HVP	FMOG with pulse output	ALU	left
SPE-FMOG-PEEK-LV	FMOG without pulse output	PEEK	left
SPE-FMOG-PEEK-LVP	FMOG with pulse output	PEEK	left
SPE-FMT-CONPP	Connector kit for FMOG, ALU	PP	
SPE-FMT-CONP	Connector kit for FMOG, PEEK	PP	
SPE-FMOG-FIT	Fitting to SPE-FMOG-ALU 1x½" (2 pcs. incl.)		

\*Material of the measuring chamber, measuring chamber lid and the turbine.





## Mobile unit

- 1x AODD pump – fully resistant and configured for the chemical feed
- Filter regulator for adjustment of inlet pressure to the pump on the compressed air supply
- Mobile trolley CLM 250, Yellow
- Valves, fittings piping and hoses – material PVC and PP or others on request
- Hoses with cam-lock for easy connection to the pump

## Safety Cabinet for AODD

- 1xAODD pneumatic diaphragm pump – fully corrosion resistant and configured for the chemical feed
- PE wall mounted cabinet with pump and extra options pre-assembled and tested
- Suspension fittings for hoses are included
- All options according to the chosen pump configuration and dimensions
- Extra options such as electric boxes, sump detector and instrumentation
- Drain valve for cabinet (delivered separately)



## Process Unit

- Intermediate Bulk Container (IBC) Storage Unit
- Collection tray - total volume corresponds to the volume of the receiver tank and the IBC (max total load 2000 kg) – material PE-HD (black)
- Pedestal for one ICB and for improved emptying – material PE-HD (black)
- Receiver tank – with flat tank top and
  - i) Outlet nozzle with dip pipe and DN15
  - ii) Inlet nozzle (in cyl.) with ball valve and hose fitting
  - iii) level pipe transparent (PVC) with magnetic float (PP)
  - iv) Vent. nozzle DN 50 & insect grid
  - v) Inspection hole
  - vi) Reserve nozzle with screw connection DN25 – material PE-HD (black)
- Connection set for IBC outlet – ball valve DN25, 2m pvc hose d32, 2x VA-hose clamps, 1x elbow 90° with union nut and hose nozzle, 1x turned part
- Fittings and pipes: PVC, seals: EPDM or FPM





## Three year limited warranty

---

Standard Pump Europe warrants, subject to the conditions below, through either Standard Pump Europe, its subsidiaries, or its authorized distributors, to repair or replace free of charge, including labor, any part of this equipment which fails within three years of delivery of the product to the end user. Such failure must have occurred because of defect in material or workmanship and not as a result of operation of the equipment other than in accordance with the instructions given in this material. Specific exceptions include:

- Consumable items such as motor brushes, bearings, couplings and impellers. (Motor brushes typically have a life span of approximately 250 hours. This will vary with the manner in which the motor is used)

Conditions of exceptions include:

- Equipment must be returned by prepaid carriage to Standard Pump Europe, its subsidiary or authorized distributor.
- All repairs, modifications must have been made by or with express written permission by Standard Pump Europe, its subsidiary or authorized distributor
- Equipment which have been abused, misused, or subject to malicious or accidental damage or electrical surge are excluded.

Warranties purporting to be on behalf of Unibloc Hygienic Technologies, LLC. made by any person, including representatives of Unibloc Hygienic Technologies, LLC, its subsidiaries, or its distributors, which do not fall within the terms of this warranty shall not be binding upon Unibloc Hygienic Technologies, LLC. unless expressly approved in writing by a Director or Manager of Standard Pump Europe. Information for returning pumps Equipment which has been contaminated with, or exposed to, bodily fluids, toxic chemicals or any other substance hazardous to health must be decontaminated before it is returned to Unibloc Hygienic Technologies, LLC, or its distributor. A returned goods authorization number (RGA #) issued by Standard Pump Europe, its subsidiary or authorized distributor, must be included with the returned equipment. The RGA # is required if the equipment has been used. If the equipment has been used, the fluids that have been in contact with the pump and the cleaning procedure must be specified along with a statement that the equipment has been decontaminated.

**STANDARD PUMP**  
*Europe*

Rønnekrogen 2  
3400 Hillerød  
Denmark

Tel +45 7023 2100

[www.standard-europe.eu](http://www.standard-europe.eu)

# PlusAir

– the brand of air-operated double diaphragm (AODD) pumps

**PlusAir** is a product line of Standard Pump Europe and offers a wide range of AODD pumps for many different industries, e.g. Automotive, Chemicals, Paints, Inks or Wastewater to meet requirements in all industries.

**PlusAir** pumps are made by one of the world-wide leading pump manufacturers who has more than half a century of experience in developing and making AODD pumps.

**PlusAir** AODD pumps ranging from the light weight Polypropylene (1,3 kg) version with a maximum capacity of 11,7 L/min, to the Stainless Steel version (104 kg) with a maximum capacity of 814 L/min.

**PlusAir** pumps are available in Polypropylene, Groundable Acetal, Aluminium, Stainless Steel, Cast Iron and PVDF.

**PlusAir** FDA Compliant Pumps are specifically designed for Food Ingredients, Pharmaceutical & Cosmetic applications where 3A, USDA or EHEDG Standards are not required.

**FDA** All FDA pumps include 316SS passivated satin finished housings, PTFE check valves and capped sanitary center disks. Pumps with aluminum motor become grey PTFE coating. 10RA to 20RA interior Mechanical polish available for some models.

**Ex** AtEx certified pumps are available in many different sizes and many body and diaphragm materials

For further details please contact your local distributor or Standard Pump Europe.



## Additional Markets Served

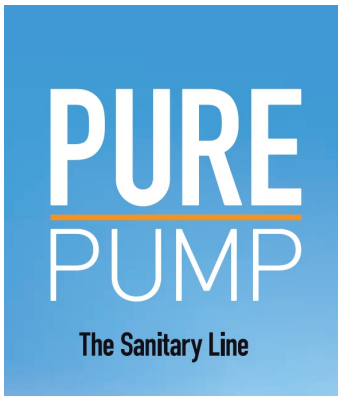

The sanitary line from Standard Pump Europe, is the perfect solution for all transportation of liquids and high viscosity ingredients in the food and pharmaceutical industry.

All pumps within our PURE PUMP series are available from local distributors all over Europe. Our distributors can help you answering technical question as well as support you in the correct pump selection for your application. Fast delivery time from the European warehouse in Denmark.

- Certificates
  - FDA
  - 3A
  - ATEX
- Surface: 32 Ra ( $\mu\text{m}$ )
- Tri-clamp connection. Optional hose connection
- Long lasting ball bearings
- Centrifugal pumps are designed without shaft seal – dry running and high back pressure allowed
- Impellers and rotors made from SS 316L
- Tri-clamp connections offers fast disassembly and cleaning



Drum pumps and AODD pumps for food-, pharmaceutical and cosmetic industry.

### Sanitary AODD Pump



### Drum Pump



Standard Pump Europe offer pump solutions for almost all industries and applications



PHARMACEUTICAL



BIOTECH



COSMETIC



FOOD



BEVERAGE



POULTRY

# QUANTM™

– the brand of electric-operated double diaphragm (EODD) pumps

Graco QUANTM™ isn't just another electric pump: it's a game-changer!

QUANTM features a revolutionary electric motor design that will reduce operational costs and keeps your production lines running. It is a perfect fit for nearly any fluid applications and a drop-in replacement for existing pumping technologies.

QUANTM is quieter, lighter, more reliable, and easier for anyone in your team to maintain.

QUANTM is available in both **Industrial-** and **Hygienic versions.**

## Benefits of QUANTM - Electric Operated Double Diaphragm Pump?

- QUANTM Operates Like AODD Pumps, While Enjoying the Benefits of an Electric Drive
- Competitive Cost Compared to AODD pumps
- No Gear Box Required
- Quiet
- No Freezing
- QUANTM use up to 8X Less Energy than an AODD.
- Reduce or Eliminate High Energy Consuming Air-Compressors and see an ROI in Less than 24 Months!
- Built-in Controls
- Operates Remotely (4-20mA)



**INDUSTRIAL**

**HYGIENIC**

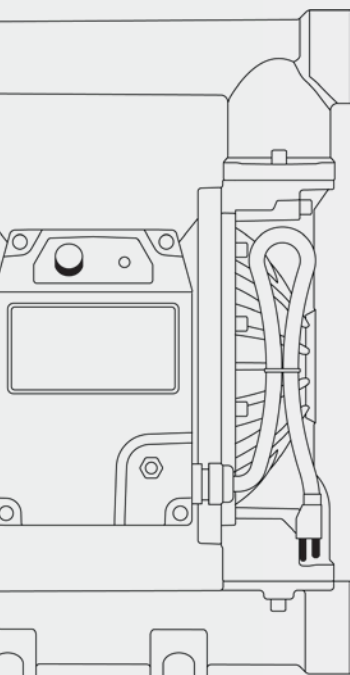

### PUMP OPTIONS

<b>Wetted Section</b>	Aluminum, SST, Poly, PVDF, Cast Iron, Hastelloy	SST
<b>Internals</b>	Same as AODD line	
<b>Connection type</b>	NPT, BSPT, ANSI Flange	Tri Clamp, DIN

### TECHNICAL SPECIFICATIONS

<b>Porting Size</b>	1" - 2"	1" - 4"
<b>Flow Range</b>	1 - 450 L/min	
<b>Working Pressure</b>	Up to 7 bar (100 psi)	
<b>Power</b>	240 VAC / 120 VAC, 1 Phase	
<b>Power Consumption</b>	Less than 15 Amps	



EC 1935/2004



ATEX

II 2 G Ex db IIB T4 Gb



### Mixers, Gear driven agitators

Standard Pumps Europe offers a range of mixers and agitators.

The reliable mixers are intended for e.g. chemicals and other media with water-like viscosity. The mixers are made of stainless steel versions coated with PP, PVC and / or PVDF to achieve the best chemical resistance.

A range of both standard gear-driven agitators and special designs for viscous media up to max. 6,000 mPas.

The different gear types come from leading German manufacturers, which ensures reliability and a high quality agitator.



- High Speed Mixers
- Gear Drive Agitators
- IBC Container Mixers
- Stands- & Lifting Equipment
- Agitator Elements
- Storage- & Dosing tanks
- Heating









# INDUSTRIAL PUMP

## Additional Markets Served:



Pure Pump  
The Sanitary Line



Pure Pump  
AODD Series



AODD Pumps  
Industrial and  
FDA compliant



EODD Pumps  
Industrial and  
FDA compliant



AdBlue  
DEF Pumps



***Safety Comes Standard™***

**STANDARD PUMP**  
*Europe*

Rønnekrogen 2  
3400 Hillerød  
Denmark

Tel +45 7023 2100

[www.standard-europe.eu](http://www.standard-europe.eu)

Distributed By:

